

FIREFLY



INTEGRATIONS

Tech Troubleshooting Guide

Version 4



Imagination ~ Innovation ~ Integration

1013 Elroy Drive, Middlebury, Indiana 46540 (574) 825-4600

2 **TABLE OF CONTENTS**

SWITCH PANELS

3 SWITCH PANELS - WIRELESS

5 SWITCH PANELS – WIRED

POWER DISTRIBUTION PANELS

8 G6A

10 G7A

12 G8

14 G9

16 G12

17 G5A

19 G5D

23 POWER MANAGEMENT MODULE (PMM)

CLIMATE CONTROL

25 AIRCON MODULES

26 VENT FAN MODULES

27 HCR12 HVAC MODULES

SLIDES

28 SLIDE CONTROLS

SHADES

30 G5A SHADE MODULES

TOUCHSCREENS

32 4.3” SCREENS

34 5” LYNX SCEEN

35 7” SPECTRUM SCREENS

37 7” LYRA SCREENS

38 10” POLARIS SCREENS

39 10” and 7” ORION SCREENS

45 VEGATOUCH SCREEN REPLACEMENT

WIRELESS MODULES

47 Eclipse

59 MIRA

63 PLUTO

NETWORK TROUBLESHOOTING

64 NETWORK TROUBLESHOOTING

66 TECH SUPPORT CONTACT INFO

67 WARRANTY PROCEDURES



WIRELESS SWITCH PANELS (SSP17)

Pushing any button on the Wireless Switch panels should cause the Green LED, located bottom center, to illuminate.

- If the LED illuminates – Battery is good
- If you have No light – ensure that the paper “remove” tab has been removed from the back of the switch panel.
- If it still does not light, replace the battery.



If no switch panel buttons activate their respective circuits - check Switch Pairing.

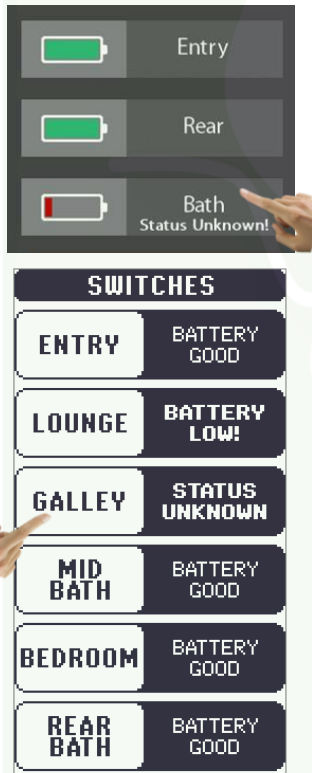

To check Switch Pairing, go to the settings page on the touch screen and tap Switch Info. If the switch is paired and has a good battery, you will see a battery status symbol.

Status Unknown indicates that either the battery is dead, or the switch panel has lost connection to the touchscreen. Once you have verified that the battery is good, follow these pairing instructions:

1. From the switch info page, locate the switch that needs paired and press and hold on the switch name (not the battery icon) for 7 seconds.
2. Choose Start Pairing.
3. You will now have 30 seconds to walk to the switch and press any 2 buttons simultaneously for 2 seconds.
4. Test the switch panel to see if it functions. Note: it may take up to 10 minutes before the Status Unknown message will disappear from the touchscreen, but the switch will work instantly.

If the switch is still not working, verify that other switches in the coach are working. If others are indeed working, move the defective switch closer to the touchscreen to see if it will start working. If it works closer to the screen, call Firefly for Tech Support. If it does not work at this point, replace the switch. *

Many screens will have a coach graphic that will show status and approximate locations of each wireless switch panel in the coach.

The switch Battery Graphic will identify the status of the wireless switch panel.



Green Switch Graphic – the switch is currently connected to the screen.



Red Switch Graphic - The switch is currently disconnected from the screen. It is likely that the battery inside your switch panel needs replaced. The wireless switch panel in your coach will illuminate a green LED whenever a button is pressed. If the LED on your switch panel does not illuminate when you press a button on your switch, you will need to replace the 2032 coin cell battery.

If a new battery will not fix the issue, you might need to pair the switch panel to the screen.

1

Press and Hold a red switch graphic for up to 7 seconds until the pairing screen appears.

2

Tap Start Pairing. You'll have 30 seconds to press any 2 buttons on the switch panel at the same time for 2 seconds.

3

Tap Done once the pairing successful message appears. It may take up to 10 minutes for the wireless switch graphic to turn Green, but the switch should work instantly once paired.

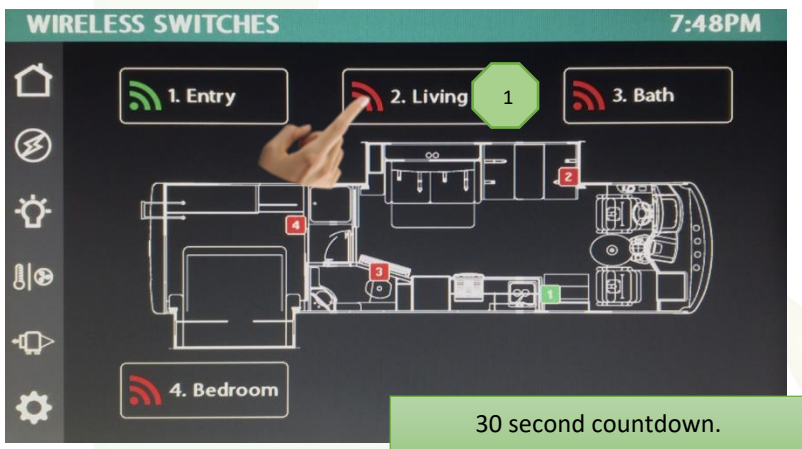



WIRED RVC SWITCH PANELS

Network Connection

RVC switches are connected to the CAN network by cables called “drop cables.” The red and black wires supply power to the switch while the blue and white wires provide communication to the network. Many switch panel issues can be caused by loose wiring at this connector known as the Mini Plug. Please see the Network Pinout diagram. It is important to note that occasionally the blue wire may be green.

Some switches will have a built-in network cable known as a pig tail. Other switches will have a female mini socket on the back and will not have a pig tail attached.

When a wired switch panel is connected to the network, a network status LED light will illuminate solid green. This NET LED will be located underneath the bezel of the switch panel. **If the NET LED status is anything other than solid green, please refer to the Network Troubleshooting Page.**

Testing Switches

Test a wired switch by removing it from the wall and plugging it directly into the Net Port. This will help to rule out wiring issues. If the switch works while it is plugged directly in, you’ll know that the switch isn’t defective. You’ll then want to investigate the wiring.



Network Pinout

- Red – 12V positive
- White – CAN High
- Blue/Green – CAN Low
- Black - Ground



NET LED

Removing the Bezel
Note: The cover for each switch panel is removed through inserting a small screw driver or using a finger to gently pry off.

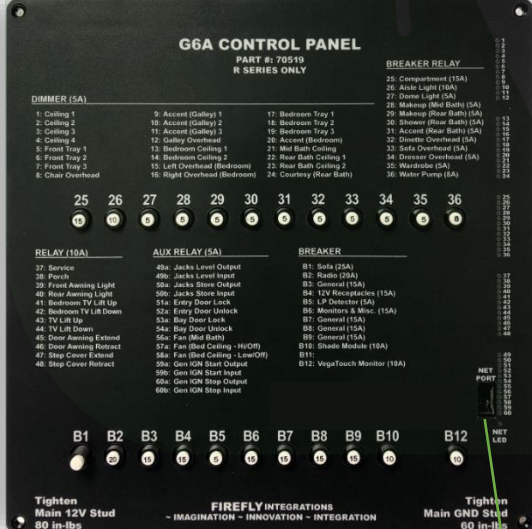

G6A CONTROL PANEL
PART #: 70519
R SERIES ONLY

DIMMER (5A)

1: Ceiling 1	9: Accent (Gallery) 1	17: Bedroom Tray 1	25: Compartment (15A)
2: Ceiling 2	10: Accent (Gallery) 2	18: Bedroom Tray 2	26: Aisle Light (10A)
3: Ceiling 3	11: Accent (Gallery) 3	19: Bedroom Tray 3	27: Dome Light (5A)
4: Ceiling 4	12: Ceiling Overhead	20: Accent (Rear Bath) (5A)	28: Makeup (Mid Bath) (5A)
5: Front Tray 1	13: Bedroom Ceiling 1	21: Mid Bath Ceiling	29: Makeup (Rear Bath) (5A)
6: Front Tray 2	14: Bedroom Ceiling 2	22: Rear Bath Ceiling 1	30: Shower (Rear Bath) (5A)
7: Front Tray 3	15: Left Overhead (Bedroom)	23: Rear Bath Ceiling 2	31: Accent (Rear Bath) (5A)
8: Chair Overhead	16: Right Overhead (Bedroom)	24: Courtyard (Rear Bath)	32: Shower Overhead (5A)

RELAY (10A)

37: Service	49a: Jacks Level Output	B1: Sofa (25A)
38: Porch	49b: Jacks Level Input	B2: Radio (20A)
39: Front Awning Light	50a: Jacks Store Output	B3: General (15A)
40: Rear Awning Light	50b: Jacks Store Input	B4: 12V Receptacles (15A)
41: Bedroom TV Lift Up	51a: Entry Door Lock	B5: LP Detectors (5A)
42: Bedroom TV Lift Down	52a: Entry Door Unlock	B6: Monitors & Misc. (15A)
43: TV Lift Up	53a: Bay Door Lock	B7: General (15A)
44: TV Lift Down	54a: Bay Door Unlock	B8: General (15A)
45: Door Awning Extend	55a: Fan (Mid Bath)	B9: General (15A)
46: Door Awning Retract	57a: Fan (Bed Ceiling - HI/Off)	B10: Stereo Modules (10A)
47: Strip Covers Extend	58a: Fan (Bed Ceiling - Low/Off)	B11: General (15A)
48: Strip Covers Retract	59a: Gen IGM Start Output	B12: VegaTouch Monitor (10A)
	59b: Gen IGM Start Input	
	60a: Gen IGM Stop Output	
	60b: Gen IGM Stop Input	

BREAKER RELAY

25: Compartment (15A)
26: Aisle Light (10A)
27: Dome Light (5A)
28: Makeup (Mid Bath) (5A)
29: Makeup (Rear Bath) (5A)
30: Shower (Rear Bath) (5A)
31: Accent (Rear Bath) (5A)
32: Shower Overhead (5A)
33: Sofa Overhead (5A)
34: Dressing Overhead (5A)
35: Wardrobe (5A)
36: Water Pump (5A)

BREAKER

B1: Sofa (25A)
B2: Radio (20A)
B3: General (15A)
B4: 12V Receptacles (15A)
B5: LP Detectors (5A)
B6: Monitors & Misc. (15A)
B7: General (15A)
B8: General (15A)
B9: General (15A)
B10: Stereo Modules (10A)
B11: General (15A)
B12: VegaTouch Monitor (10A)

NET PORT

NET LED

Tighten Main 12V Stud 60 in-lbs

FIREFLY INTEGRATIONS
- IMAGINATION - INNOVATION - INTEGRATION

Tighten Main GND Stud 60 in-lbs

Switches that don’t have a pig tail will require the use of a separate network cable to test at the Net Port. This type of switch can also be tested by removing a working switch and testing at its location.

Net Port – allows direct access to the network

A SWITCH PANEL HAS GONE DARK AND NO LONGER FUNCTIONS.

Remove the switch panel from the wall. Do the network wires seem like they have a loose connection or has one of the wires come loose?

- Yes – repair the wiring and retest the switch
- No – remove the switch from the wall and plug it directly into the power distribution center’s Net Port to test (G5, G6, etc.).

Does it work while plugged in directly to the Net Port?

- Yes – There may be a problem with the wiring running to the switch. Check all connections in the wiring running to the switch.
- No – Replace the switch. *

MULTIPLE SWITCH PANELS HAVE GONE DARK AND NO LONGER FUNCTION.

Remove the switch panels from the wall. Do the network wires seem like they have any loose connections or has one of the wires come loose?

- Yes – repair the wiring and retest the switches
- No – remove the switches from the wall and plug them directly into the power distribution center’s Net Port to test (G5, G6, etc.).

Do they work while plugged in directly to the Net Port?

- Yes – Check all connections in the wiring running to the switch. Identify if all of the switches are plugged into the same Network Tap. Locate the network tap to identify if it has a solid green LED. If it doesn’t have a solid green LED, check the wiring to the Network Tap. Replace the Network Tap if necessary. *
- No – Replace the switches. *



A SWITCH PANEL HAS A FLASHING NET LED.

Remove the switch panel from the wall. Do the network wires seem like they have a loose connection or has one of the wires come loose?

- Yes – repair the wiring and retest the switch.
- No – plug the switch panel into the power distribution panel’s Net Port.

Does the NET LED turn Solid Green when plugged into the Net Port?

- Yes – investigate the wiring leading to the switch panel.
- No – replace the switch panel. *

MULTIPLE SWITCH PANELS HAVE A FLASHING NET LED.

See the Network Troubleshoot Guide and perform a Network Resistance Test. Call Firefly Integrations for tech support if you do not measure 60 ohms.

A BUTTON ON A SWITCH PANEL NO LONGER FUNCTIONS.

You will need to ensure that there is not a problem with the distribution panel.

Can you operate the same function from another switch/touchscreen in the coach?

- Yes – the switch panel might be defective and could need to be replaced. Test the switch at another location to rule out the wiring to the switch. Replace the switch if necessary. *
- No – See the Distribution Panel Troubleshooting page.

A SWITCH PANEL LIGHTS UP BUT NO BUTTONS WILL FUNCTION.

Remove the switch panel and check the network connections and the NET LED status. It is likely that one of the communication wires have come loose. If all connections look solid, test the switch in the power distribution center's Net Port. Does it work while plugged in directly?

- Yes – There may be a problem with the wiring running to the switch. Check all connections in the wiring running to the switch.
- No – Replace the switch. *



DC Power Distribution Panels

G6A Panel

The G6A control panel is the most common type of power distribution center. This panel receives the signals sent from your switch panels and performs the actions that have been requested by activating and deactivating the required circuits.

Every circuit controlled by the G6A is numbered and listed on the front label (load list). A corresponding numbered LED will illuminate green whenever a particular circuit is on. For instance, if you press the Lounge Light button on your switch panel, the green LED beside circuit 1 will illuminate and the Lounge Light will turn on (Fig 1).

Resettable breakers are also numbered and listed on the G6A label. Simply press the white tip to reset a breaker if one has tripped.



NET LED

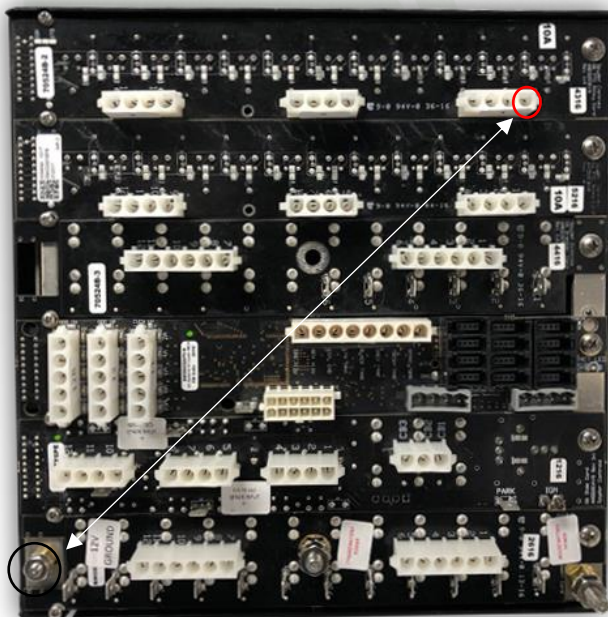

Testing output voltage using a Multi-meter.

Ensure that the G6 circuit is on and that the green LED is illuminated.

To test the output voltage for the Lounge Light example, touch the positive lead to the output pin for Circuit 1 and the negative lead to the ground stud (as pictured).

If you do not measure at least 12v it is likely that the relay card in the G6 will need to be replaced. *

A GREEN LED ON THE G6 WON'T ILLUMINATE WHEN A BUTTON IS PRESSED ON A SWITCH PANEL.

Ensure that other functions on the switch panel are working and all system Net LED's are solid green. Test the light from another device or location if possible. If the switch panel is not defective, the green LED on the G6 should illuminate when the button is pressed on a switch panel. If you have determined that the switch isn't defective, it is likely that the G6 driver card has an issue and the G6 would need to be replaced. *

THE GREEN CIRCUIT LED FOR A PARTICULAR LIGHT WILL ILLUMINATE, BUT THE LIGHT IN THE COACH IS NOT WORKING.

Let's use the example from the previous page. In this scenario, the Lounge Light button is pressed but the Lounge Light (Ceiling 1) will not turn on in the coach.

First, check the switch panel button for feedback? Did the switch panel button change color?

- Yes – Continue reading.
- No – Troubleshoot the network or the switch panel itself before continuing.

Look at the load list on the G6A panel. Is the Green LED beside circuit 1 illuminated?

- Yes – the G6 has received the signal from the switch panel. Test the outputs for Circuit 1 on the back of the G6 for 12v output. If an output of 12v is measured, the firefly system is working correctly and the coach wiring will need to be investigated.
- No – Ensure that the switch is not defective. Test with a different switch or plug the switch directly into the Net Port to help determine if the switch has a problem. It is possible that the G6 has a faulty driver card and would need to be replaced. *

LIGHTS ARE COMING ON IN THE COACH WITHOUT BEING ACTIVATED BY A SWITCH PANEL OR LIGHTS IN THE COACH WILL NOT SHUT OFF.

Shut down 12v power to the coach (power cycle) for 10 seconds. Did the lights come back on automatically when power was returned to the coach?

- Yes – Remove all switch panels from the network that control those particular lights and power cycle the coach again. If the lights still turn on by themselves once power has been reapplied to the coach, check the Green LED on the G6. If it is on, you probably have a faulty driver card and the G6 will likely have to be replaced. * If it is off, check the output voltage on the back of the G6 for the circuits in question. If you are measuring 12v on the circuits in question while the Green LED is off, you will need to replace the card in question. * You should not be getting an output while the G6 circuit LED is off.
- No – Plug the switches back into the network one at a time to see if they successfully operate. If a switch operates successfully, leave it plugged in. Add the rest of the switches back into the network one at a time. If any lights automatically turn on once a switch is connected, that switch is defective. *

G7 Panel

The G7 control panel is another common type of power distribution center. This panel receives the signals sent from your switch panels and performs the actions that have been requested by activating and deactivating the required circuits.

Every circuit controlled by the G7 is numbered and listed on the lid (load list). A corresponding LED will illuminate green whenever a particular circuit is on. For instance, if you press the Living Room Ceiling Light button on your switch panel, the green LED beside connector 1 pin 1 will illuminate and the Living Room Ceiling Light will turn on (Fig 2).

Unlike the G6A panel, the G7 panel does not use resettable breakers.

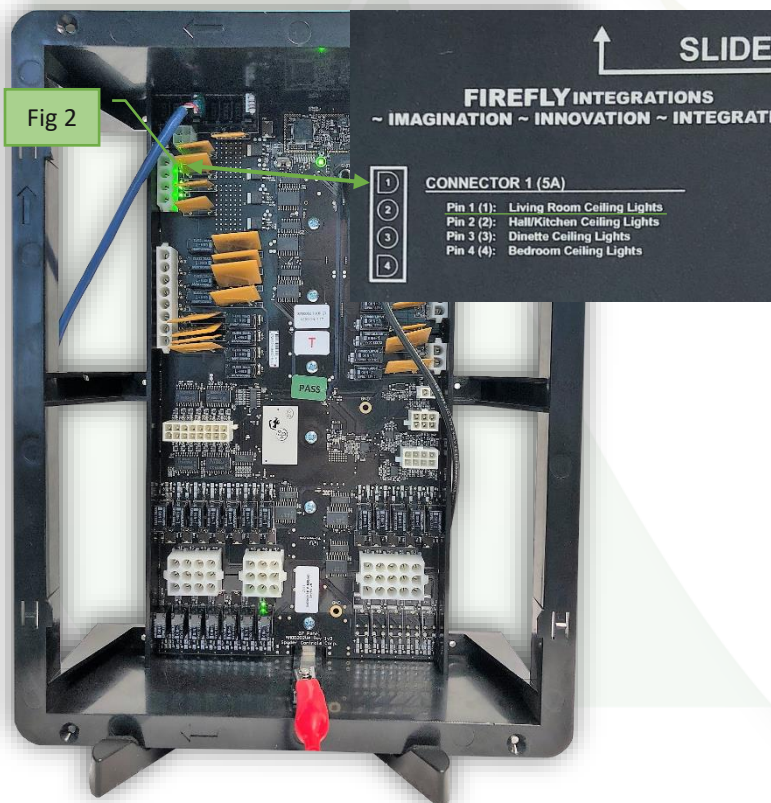
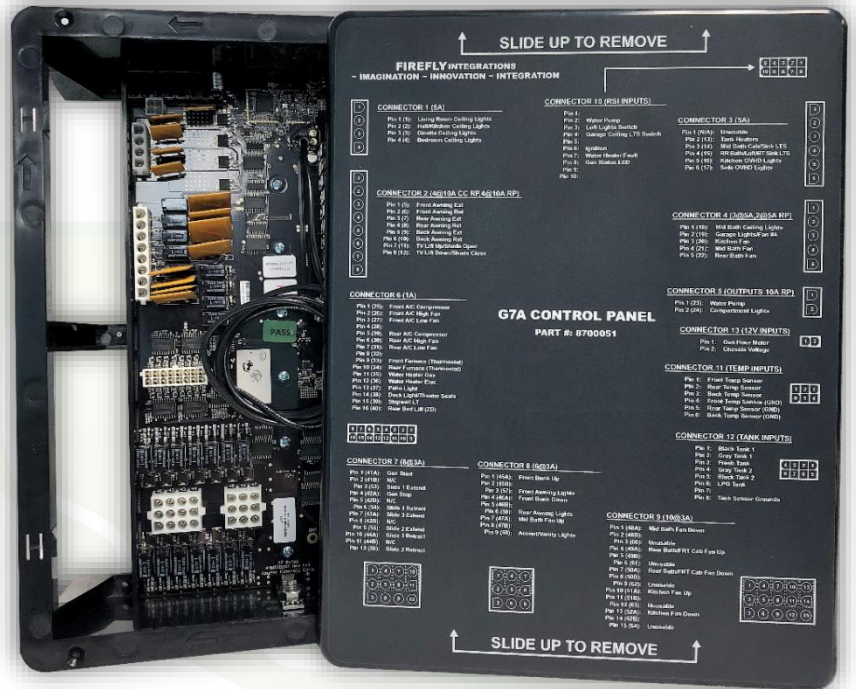

CONNECTOR 1 (5A)
 Pin 1 (1): Living Room Ceiling Lights
 Pin 2 (2): Hall/Kitchen Ceiling Lights
 Pin 3 (3): Dinette Ceiling Lights
 Pin 4 (4): Bedroom Ceiling Lights

NOTE: ALWAYS POWER CYCLE THE 12V POWER TO THE COACH BEFORE TROUBLESHOOTING.

Simply flip the battery disconnect switch for 10 seconds and turn it back on. A power cycle can fix many problems that seem out of the ordinary.

NOTHING HAPPENS WHEN A BUTTON IS PRESSED ON A SWITCH PANEL OR FROM THE TOUCHSCREEN.

Verify that the NET LED is illuminated solid green on the G7. If the NET LED is flashing, perform a power cycle and check the NET LED again. If the NET LED is displaying anything other than solid green, see the Network Troubleshooting guide.

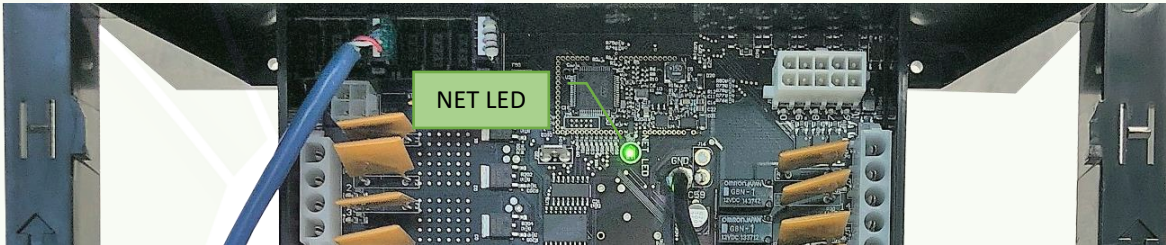

A BUTTON ON A SWITCH PANEL NO LONGER FUNCTIONS.

Typically G7 panels are used with wireless SSP17 switch panels. Please refer to SSP17 troubleshooting on Page 2.

A FUNCTION WILL NOT WORK FROM THE TOUCHSCREEN.

In this example, we will assume that you are attempting to turn on the Living Room Ceiling Lights. Is the screen showing feedback when you press the Living Ceiling button?

- Yes – With the circuit on, check that the circuit LED is on. Now, check the output on the G7 panel with a multi-meter to make sure that it is sending output voltage. If it is not giving 12v output, replace the G7 panel. * If it is giving output, check the coach wiring to the lights.
- No – Check the NET LED on the back of the touch screen and on the G7 to make sure that they are solid green. If they are solid green, call Tech Support.

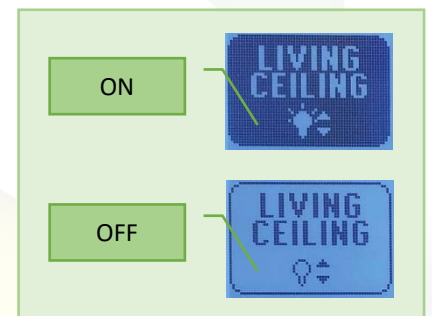

Test **Positive** Output Channels as shown:



G8 Panel

The G8 control panel is a more compact type of power distribution center. This panel receives the signals sent from your switch panels and performs the actions that have been requested by activating and deactivating the required circuits.

Every circuit controlled by the G8 is numbered and listed on a black label (load list) which is usually mounted next to the G8 panel.

A corresponding numbered LED will illuminate green whenever a particular circuit is on. For instance, if you press the Bath Light button on your switch panel, the green LED for output 11 will illuminate and the Bath Light will turn on (Fig 3).

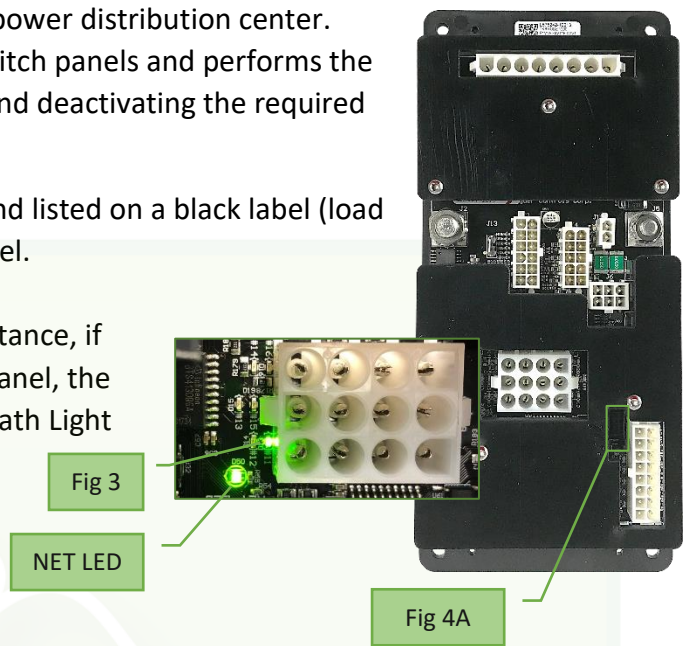

Testing output voltage using a Multi-meter.

Ensure that the G8 circuit is on and that the corresponding green LED is illuminated.

To test the output voltage for the Bath Light example, touch the **positive** lead to the output pin for output 11 (Connector J9 – Pin 7) and the negative lead to the ground stud (as pictured below).

If the corresponding LED illuminates green and you do not measure at least 12v it is likely that the G8 will need to be replaced. * Note: If you are testing with the plug connected to the G8 panel and are not getting the proper voltage, remove the plug and test the pins directly.

G8 Differences

It is important to note the differences between G8 panels. The newer style (Fig 4A) uses a removeable drop cable connection which runs to a drop tap. The older style (Fig 4B) also runs to a drop tap but the network cable is fixed and cannot be removed.

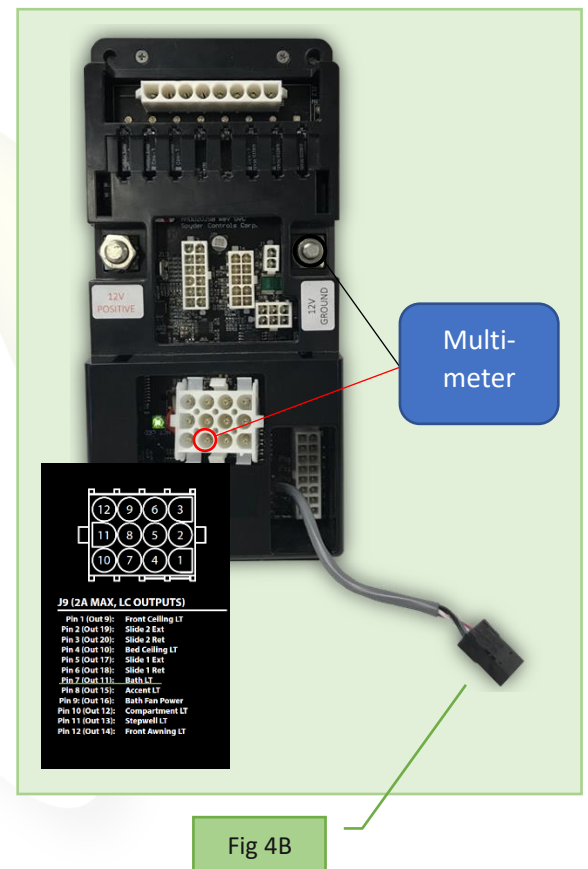

A GREEN LED ON THE G8 WON'T ILLUMINATE WHEN A BUTTON IS PRESSED ON A SWITCH PANEL.

Ensure that other functions on the switch panel are working and all system NET LED's are solid green. Test the light from another device or location if possible. If the switch panel is not defective, the green LED on the G8 should illuminate when the button is pressed on a switch panel. If you have determined that the switch isn't defective, it is likely that the G8 has an issue and would need to be replaced. *

THE GREEN CIRCUIT LED FOR A PARTICULAR LIGHT WILL ILLUMINATE, BUT THE LIGHT IN THE COACH IS NOT WORKING.

Let's use the example from the previous page. In this scenario, the Bath Light button is pressed but the Bath Light will not turn on in the coach.

First, check the switch panel button for feedback? Did the wired switch panel button change color (Wireless switch panel buttons will not show feedback)?

- Yes – Continue reading.
- No – Troubleshoot the network or the switch panel itself before continuing.

Look at the load list for the G8 panel. Is the Green LED beside output 11 illuminated?

- Yes – the G8 has received the signal from the switch panel. Test the voltage for output 11 on the G8. If an output of 12v is measured, the firefly system is working correctly and the coach wiring will need to be investigated. If less than 12v is showing and you are measuring directly on the wiring harness connector, unplug the connector and test the G8 pins directly to verify.
- No – Ensure that the switch is not defective. Test with a different switch or plug the switch directly into the Net Port to help determine if the switch has a problem. It is possible that the G8 is faulty and would need to be replaced. *

LIGHTS ARE COMING ON IN THE COACH WITHOUT BEING ACTIVATED BY A SWITCH PANEL OR LIGHTS IN THE COACH WILL NOT SHUT OFF.

Shut down 12v power to the coach (power cycle) for 10 seconds. Did the lights come back on automatically when power was returned to the coach?

- Yes – Remove all switch panels from the network that control those lights and power cycle the coach again. If the lights still turn on by themselves once power has been reapplied to the coach, check the Green LED on the G8. If it is on, replace the G8. *
- No – Plug the switches back into the network one at a time to see if they successfully operate. If a switch operates successfully, leave it plugged in. Add the rest of the switches back into the network one at a time. If any lights automatically turn on once a switch is connected, that switch is defective. *

G9 Panel

The G9 panel receives the signals sent from your switch panels and performs the actions that have been requested by activating and deactivating the required circuits.

Every circuit controlled by the G9 is numbered and listed on a black sticker (load list) which is usually mounted next to the G9 panel. Note: The G9 will not have individual illuminated NET LED's for each channel. For instance, if you press the Bath Light button on your switch panel, there will be no illuminated GREEN LED to show that it is currently operational. You will need to check output voltage on that pin if the Bath Light does not come on (Fig 5).

The NET LED will not be visible while looking directly at the front side of the G9 panel. To see the NET LED, view the panel from an angle as shown.

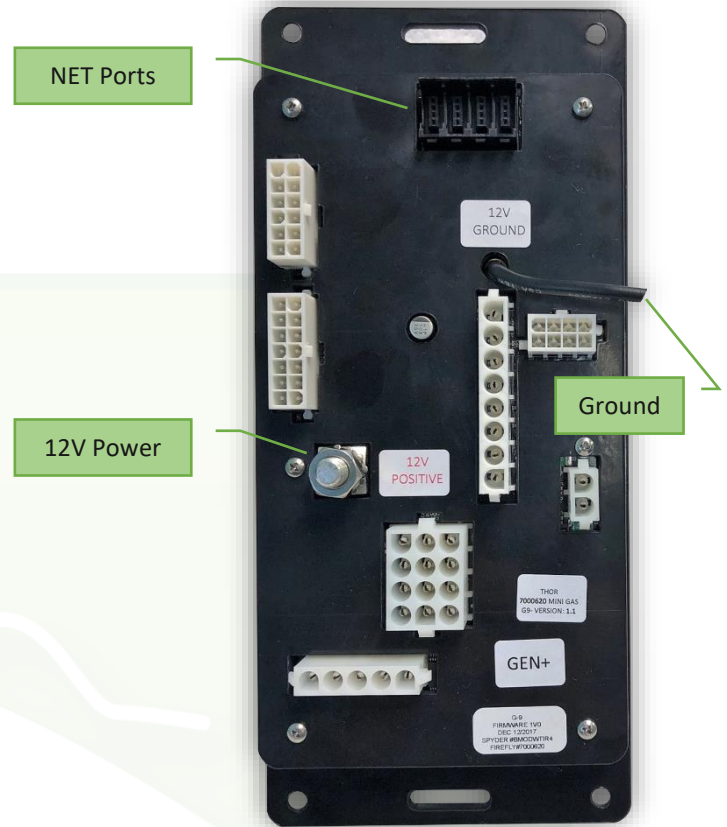

Fig 5

Test Positive Output Channels as shown:

J8: HIGH CURRENT OUTPUTS 3A		
Pin 1 (IC2 - Out 17):	Front Ceiling LTS	
Pin 2 (IC2 - Out 18):	Bed Ceiling LTS	
Pin 3 (IC3 - Out 19):	Bath LTS	
Pin 4 (IC4 - Out 20):	Rear Bath/Hall LTS	
Pin 5 (IC3 - Out 21):		
Pin 6 (IC3 - Out 22):	Door Awning Extend	
Pin 7 (IC4 - Out 23):	Door Awning Retract	
Pin 8 (IC4 - Out 24):	Awning Extend	
Pin 9 (IC3 - Out 25):	Awning Retract	
Pin 10 (IC4 - Out 26):	Cargo LTS	
Pin 11 (IC4 - Out 27):	Stepwell LTS	
Pin 12 (IC3 - Out 28):	Awning LTS	

A GREEN LED ON THE G9 WON'T ILLUMINATE WHEN A BUTTON IS PRESSED ON A SWITCH PANEL.

The only LED on the G9 is the NET LED as shown on the previous page. If the NET LED will not illuminate, verify the power going to the G9 panel and see the Network Troubleshooting guide.

THE NET LED IS ILLUMINATED, BUT THE LIGHT IN THE COACH IS NOT WORKING.

Let's use the example from the previous page. In this scenario, the Bath Light button is pressed but the Bath Light will not turn on in the coach.

First, check the switch panel button for feedback? Did the wired switch panel button change color (Wireless switch panel buttons will not show feedback)?

- Yes – Continue reading.
- No – Troubleshoot the network or the switch panel itself before continuing.

Verify the voltage of the Bath Lights output on the G9 (see Figure 1 on the previous page). If you don't measure at least 12V coming directly from the pins, replace the G9. *

LIGHTS ARE COMING ON IN THE COACH WITHOUT BEING ACTIVATED BY A SWITCH PANEL OR LIGHTS IN THE COACH WILL NOT SHUT OFF.

Shut down 12v power to the coach (power cycle) for 10 seconds. Did the lights come back on automatically when power was returned to the coach?

G9 panels will typically be used with Wireless Switch Panels. Continue reading for Wired Switch Panels.

- Yes – Remove all wired switch panels from the network that control those particular lights and power cycle the coach again. If the lights still turn on by themselves once power has been reapplied to the coach, check the output voltage for circuit in question on the G9. If it is giving an output, replace the G9. *
- No – Plug the wired switches back into the network one at a time to see if they successfully operate. If a switch operates successfully, leave it plugged in. Add the rest of the switches back into the network one at a time. If any lights automatically turn on once a switch is connected, that switch is defective. *

G12 Panel

The G12 control panel is our newest model of power distribution center. This panel receives the signals sent from your switch panels and performs the actions that have been requested by activating and deactivating the required circuits.

Every circuit controlled by the G12 is numbered and listed on a black sticker (load list) which is usually mounted next to the G12 panel. Note: The 12 will not have individual illuminated NET LED's for each channel. For instance, if you press the Bath Light button on your switch panel, there will be no illuminated GREEN LED to show that it is currently operational. You will need to check output voltage on that pin if the Bath Light does not come on (Fig 6).

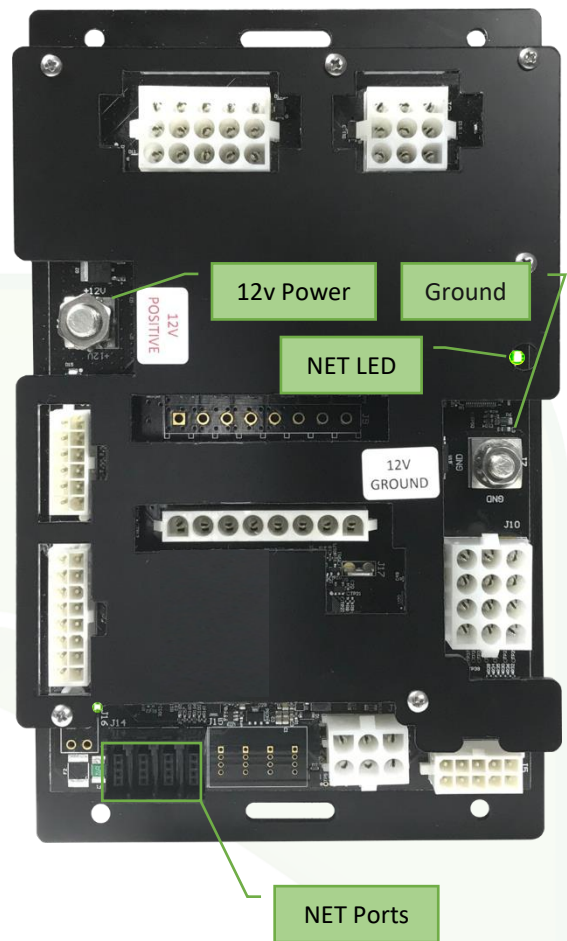

G5A DC Panel

The G5 DC Panel series is quite common in older coaches. The system does not use resettable breakers, but instead uses mini fuses on each channel.

Channels 1-24 are not controlled by switch panels. These channels are fused on the panel only. If a function stops responding on one of these channels, test and replace the fuse if necessary.

Replacement Fuse – Mini-Blind Type
(Littlefuse 257 series or Bussman ATM series)
15A Max Fuse – Channels 1-8 & 17-24

Channels 25-36 are Dimming Outputs

- Green Indicator = Channel on, Fuse good.
- Red Indicator = Channel On, Fuse blown.
- No indicator = Channel off

Channels 37-44 AUX Relay Outputs

- Green Indicator = Channel on
- No indicator = Channel off

Note: A built-in 3A auto-reset PTC fuse for each channel provides over-current protection. The indicator DOES NOT show when this fuse is open or in short-circuit condition.

Channels 45-64 Relay Outputs

- Green Indicator = Channel on
- Red Indicator = Channel On, Fuse blown
- No indicator = Channel off

(Littlefuse 257 series or Bussman ATM series)

Channels 1-24 Unswitched/Fused Outputs

- Red Indicator On = Fuse blown
- Red Indicator Off = Fuse good or no active load

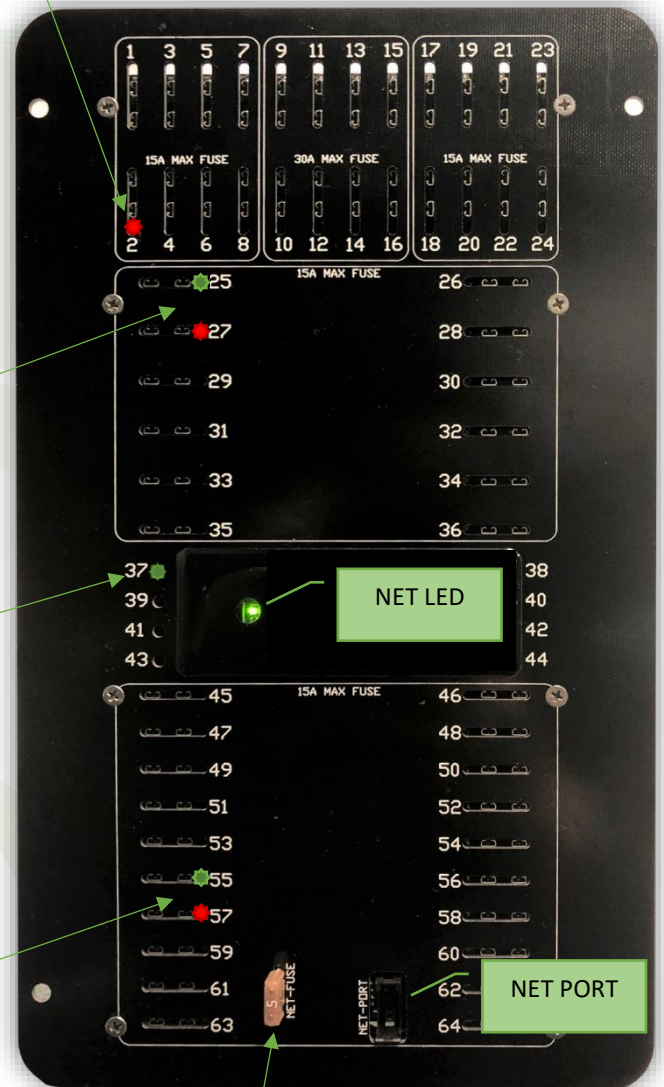

Net Fuse 5A Max – This fuse provides power to the network powered devices only (typically all switch panels). NOTE: this fuse does not have an indicator light for fuse status.

G5A Panel Rear Diagram

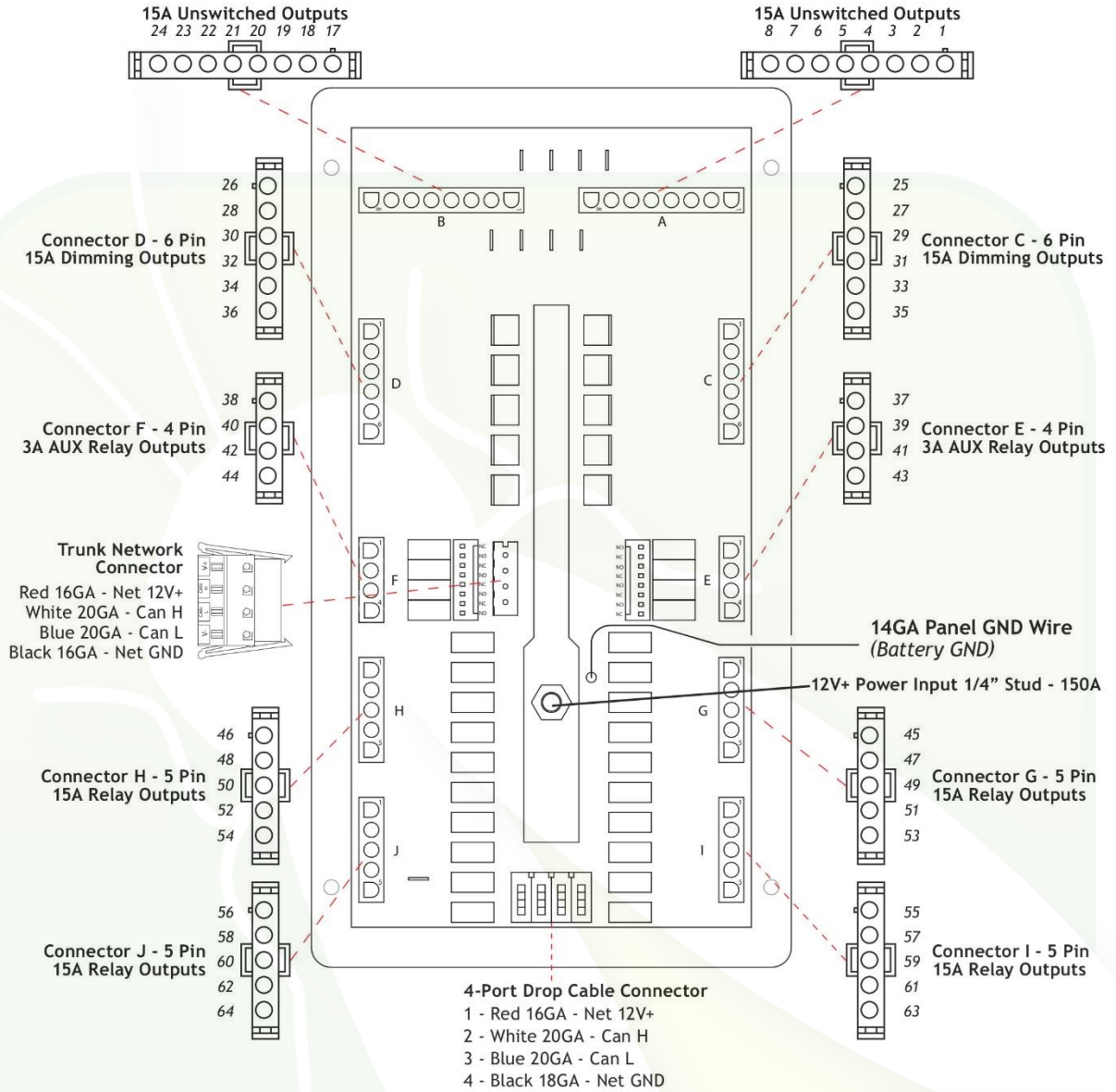

G5 Replacement – If you replace a G5 and circuits 62 and 64 will not function, you need to run 12V+ to this spade.

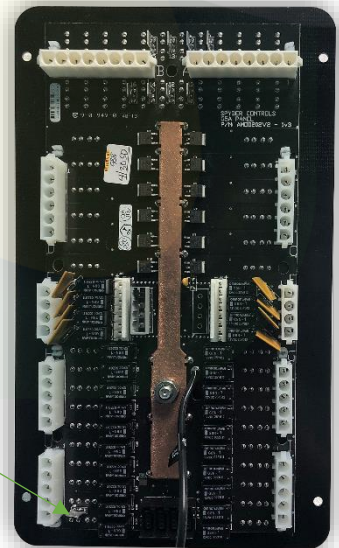

G5D DC Panel

Channels F1-F24 are not controlled by switch panels. These channels are fused on the panel only. If a function stops responding on one of these channels, test and replace the fuse if necessary.

Replacement Fuse – Mini-Blind Type
 (Littlefuse 257 series or Bussman ATM series)
 15A Max Fuse – Channels F1-F8 & F17-F24
 30A Max Fuse – Channels F9-F18

Channels F1-F24 Unswitched/Fused Outputs

- ❗ Red Indicator On = Fuse blown
- Red Indicator Off = Fuse good or no active load

Channels 1-16 are Dimming Outputs

- 🟢 Green Indicator = Channel on, fuse good
- ❗ Red Indicator = Channel On, fuse blown
- 🟡 Orange indicator = Channel on, no fuse in place
- No indicator = Channel off

Channels 17-40 Relay Outputs

- 🟢 Green Indicator = Channel on
- ❗ Red Indicator = Channel On, Fuse blown
- 🟡 Orange indicator = Channel on, no fuse in place
- No indicator = Channel off

(Littlefuse 257 series or Bussman ATM series)

Channels 41-56 AUX Relay Outputs

- 🟢 Green Indicator = Channel on
- No indicator = Channel off

Note: A built-in 3A auto-reset PTC fuse for each channel provides over-current protection. The indicator DOES NOT show when this fuse is open or in short-circuit condition.

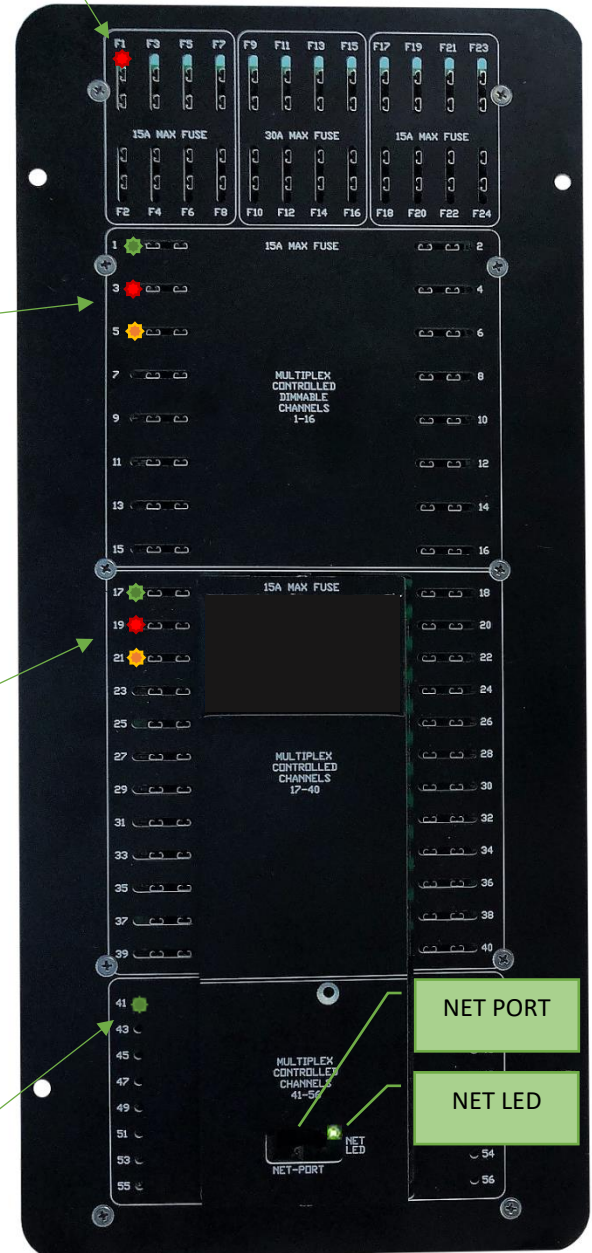

G5D Panel Rear Diagram

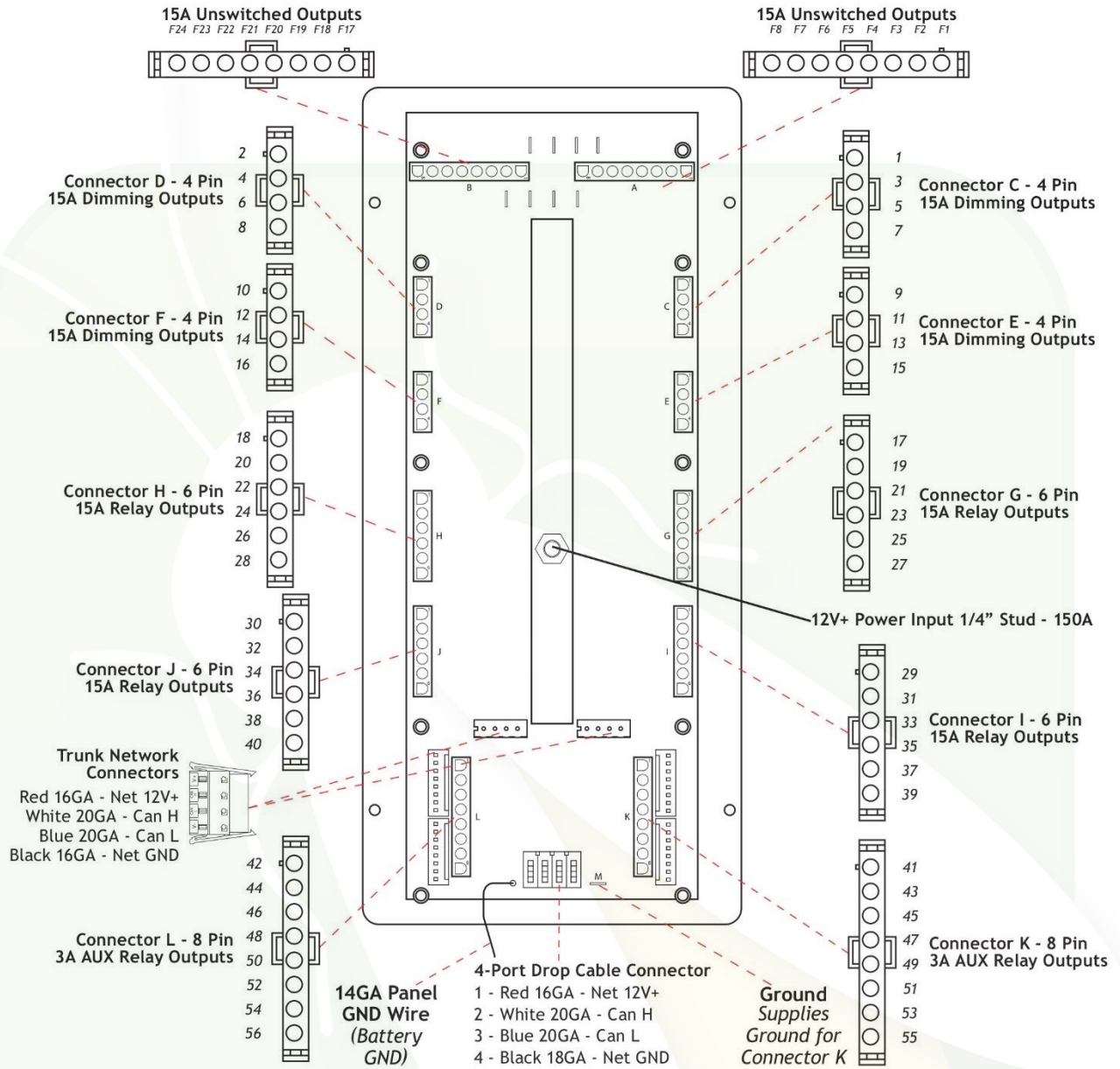

A LIGHT CIRCUIT/CHANNEL STAYS ON CONSTANTLY AND CANNOT BE TURNED OFF BY THE SWITCH PANEL.

At the G5A control panel, check to see if the GREEN indicator LED for that circuit is constantly ON even when the assigned switch is turned ON and OFF.

Always ON – Cycle the 12V Master Power OFF then ON. Note: Before pressing ANY switch panel buttons, return to the G5 Panel and check the status of the LED for the circuit in question.

- If LED is still ON, unplug the assigned connector on the rear of the G5A for the circuit/channel in question and test the voltage on the output.
 - If the Green LED is still ON and the output is still ON, replace the G5A Panel. *
 - If the Green LED is now OFF and there is no output voltage present, check the load or the wiring between the G5A panel output and the load.

Now OFF – If the Green indicator LED turns On and OFF, verify the wiring to the load or the load itself.

A LIGHT CIRCUIT/CHANNEL STAYS OFF CONSTANTLY AND CANNOT BE TURNED ON BY THE SWITCH PANEL.

Press the ON button on the switch panel that controls the circuit in question. Does the status LED on that button turn ON?

YES – Proceed to the G5A control panel and check the status of the indicator LED for that specific fuse or circuit. What color is it?

- RED – Replace the fuse and verify if the circuit now works properly.
- Green – Check the voltage for the assigned pin/wire coming out of the assigned output connector on the rear of the G5A panel.
 - If there is voltage, check the wiring between the G5A panel and the load or the load itself.
 - If there is NO voltage, check for a loose or damaged fuse or fuse holder.
- NO LED Illuminated – RE-Verify the switch panel button LED is still ON and verify that you are looking at the correct circuit on the G5A panel. If this checks out, replace the G5A. *

NO – Verify that the switch panel and the G5A are online by looking at the status of the NET LEDs.

- NET LED is RED or RED/ORANGE – See the Network Troubleshooting Guide.
- Net LED's are all SOLID GREEN – Remove the switch panel and plug it directly into the front of the G5A NET PORT.
 - If the LED indicator on the switch panel button DOES turn ON when the ON button is pressed, proceed to the Network Troubleshooting Guide.
 - If the LED indicator on the switch panel button still does not turn ON when the ON button is pressed, replace the switch panel. *

A DIMMING LIGHT CIRCUIT/CHANNEL IS ALWAYS ON DIMLY.

Press and hold the ON button to see if the light gets brighter and then HOLD the OFF button to see if the light gets dimmer. Next, press the OFF button to see if the light turns OFF.

- If lights are working as described above, everything is working properly.
- If the lights dim up and down but do not turn OFF, continue reading.

At the G5A control panel, check to see if the GREEN indicator LED for that circuit/channel is constantly on, even when the assigned switch is turned ON and OFF.

LED ALWAYS ON – Cycle the 12V Master power OFF and ON. Before pressing any switch panel buttons, return to the G5A panel and check the state of the GREEN indicator LED for the circuit in question.

- If LED is still ON, unplug the connector on the rear of the G5A for the circuit/channel in question and test the voltage on the output.
 - If the GREEN LED is still ON and the output is still ON, replace the G5A panel. *
 - If the GREEN LED is now OFF and there is no output voltage present, check the load or the wiring between the G5A panel output and the load.
- If the LED is now OFF, return to the switch panel/button for the circuit in question and verify it is now working.

If the GREEN indicator LED turns ON and OFF, verify the wiring to the load or the load itself.



Power Management Module (PMM)

The Power Management Module contains the coach logic and is the sole source for inputs to the RVC network (tank sensors, thermistors, etc.).

POWER CYCLE THE PMM BEFORE TROUBLESHOOTING.

Power Cycle – Turn off your House battery disconnect switch and remove the house 12V power lug from the PMM. After 10 seconds, reconnect the power lug and flip the house disconnect switch back on. This will have restarted the system.

Note: Simply disconnecting the House 12V power from a battery disconnect switch inside the coach will not restart the PMM.

Troubleshoot the system by verifying that the NET LED is solid green. If it is not, see the Network Troubleshooting page of this manual.

Troubleshooting Examples:

REAR FURNACE WON'T TURN ON

Turn on the circuit from the touchscreen and test for output voltage on Connector J10 – Output #4 Rear Furnace. If you measure less than 12v, replace the PMM. *

LPG SCREEN DISPLAY READS NEARLY FULL (98% FOR EXAMPLE) BUT THE TANK IS EMPTY.

The PMM is not reading resistance. Replace the LPG gauge.

SOME THERMISTORS ARE READING NEGATIVE DEGREES (-127° FOR EXAMPLE).

Check the wiring to connector J3. The thermistor wires are installed to the wrong pins or the wiring/thermistors are faulty or not connected. Make sure that the pins are securely pushed into their connectors.

GENERATOR HOURS AREN'T BEING SAVED TO THE SYSTEM.

Check the wire running from the generator to connector J5 – pin 2. The PMM isn't receiving a signal from the generator if the system gen hours aren't being saved.

THE WATER PUMP WON'T TURN ON.

Check the Water Pump pin on connector J2 for ground. Verify that the spade connector for J15 is plugged in.

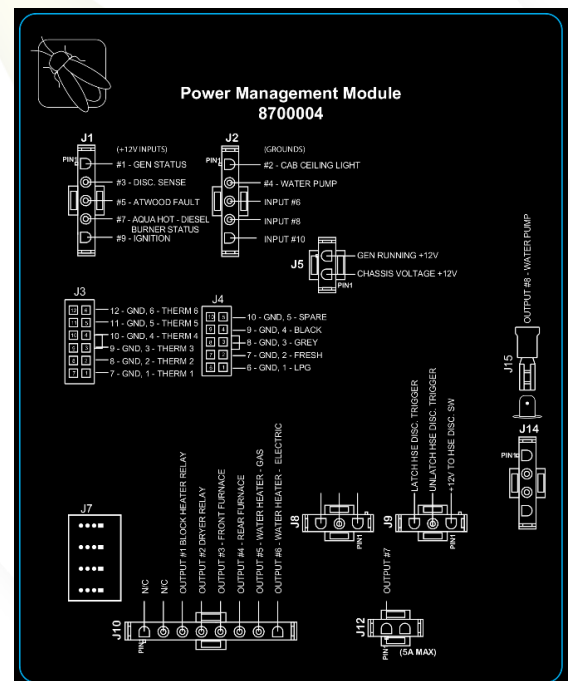
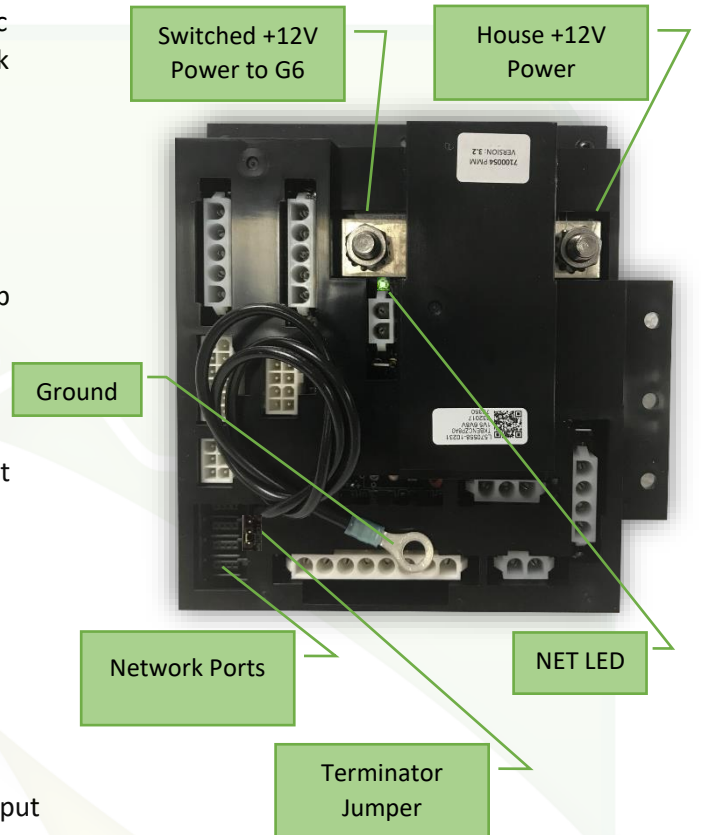

***CONTACT THE COACH MANUFACTURER FOR WARRANTY PROCEDURES.**

Terminator Jumper

If you are experiencing network issues and are not measuring 60 ohms when you measure network resistance, check the terminator jumper. If this jumper is on the wrong 2 pins, this will cause the network resistance to double. For example, a healthy network that measures 60 ohms with 2 active terminators, will measure 120 ohms of resistance if this terminator becomes disabled.

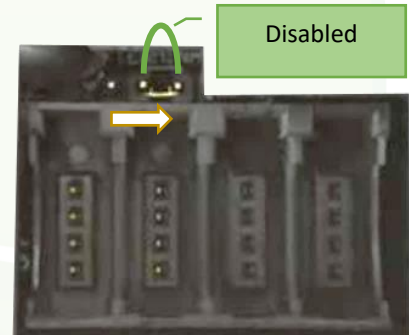
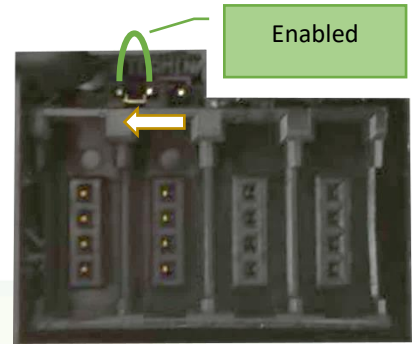



AirCon Module

The AirCon Module is designed to interface with air conditioning units in RV applications to allow them to be controlled via RV-C.

AirCons use relays to control the 120v power that goes to the compressors, fans, reverse valve, and heat strip in the AC unit. They also connect to the freeze sense inside the AC unit to be able to monitor its status and intelligently handle defrost cycling.

Up to four AirCons can be used on a single network. Each AirCon will need to be addressed individually on connector J2. See the table below for address settings.

Troubleshooting

AN AIR CONDITIONING UNIT IS TURNING ON WITH AN AC REQUEST FROM A DIFFERENT ZONE.

The AirCon has probably been addressed incorrectly. See the chart below for addressing details.

AN AIR CONDITIONER SHUTS DOWN AFTER APPROXIMATELY 30 SECONDS.

Make sure that the freeze sensor is installed correctly or replace the freeze sensor if necessary.

AN AIR CONDITIONER WILL NOT FUNCTION, BUT THE SCREEN SHOWS THAT IT IS CURRENTLY ON.

Check to make sure that the NET LED is solid green. If not, check the network wire running to the AirCon. Check to make sure that 120v power has been ran to the AirCon and that it is hooked up correctly.

Make sure that the AC override toggle switch is in the correct position.

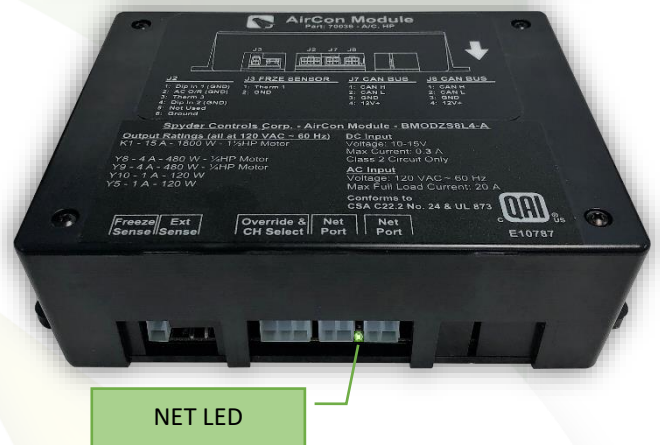
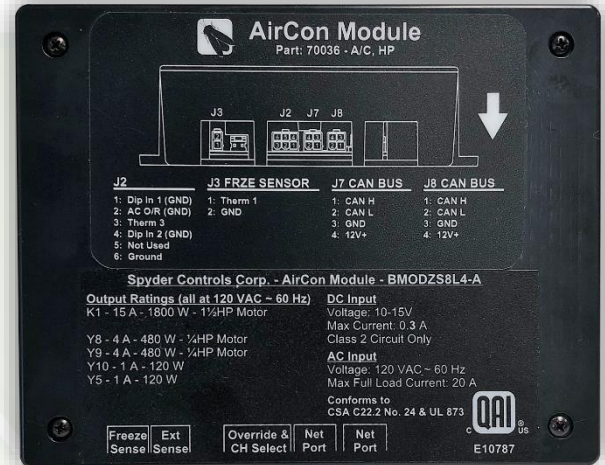

Address Chart (Connector J2)		
Address	Dip In 1	Dip In 2
1	Open	Open
2	Ground	Open
3	Open	Ground
4	Ground	Ground



Vent Fan Module

The Vent Fan Module is designed to interface with all vent fan units in RV applications to allow them to be controlled via RV-C.

Vent Fan Modules incorporate rain sensing which automatically closes lids when moisture is sensed.

Up to four Vent Fans can be used on a single network. Each Vent Fan will need to be addressed individually on connector J7. See the table below for address settings.

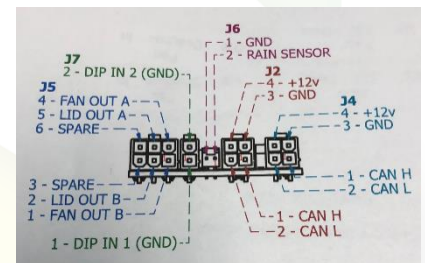

Address Chart (Connector J7)		
Address	Dip In 1	Dip In 2
1	Open	Open
2	Ground	Open
3	Open	Ground
4	Ground	Ground



HCR12 HVAC Module

The HCR12 HVAC module adds fused relays between your G6 panel and your HVAC system components.

Installation is very straightforward. Simply run Power and Ground to the module, plug in the wago connector from the G6 connections, add the required MAXI fuses, and connect the outputs that run to your HVAC components (condenser and fan speeds).

An active circuit will be identified by a Green LED that will illuminate whenever a relay is closed. If a Green LED is illuminated, that relay will be sending 12V+ to the output connection for that particular channel.

Please see the included black label for specific wiring information.

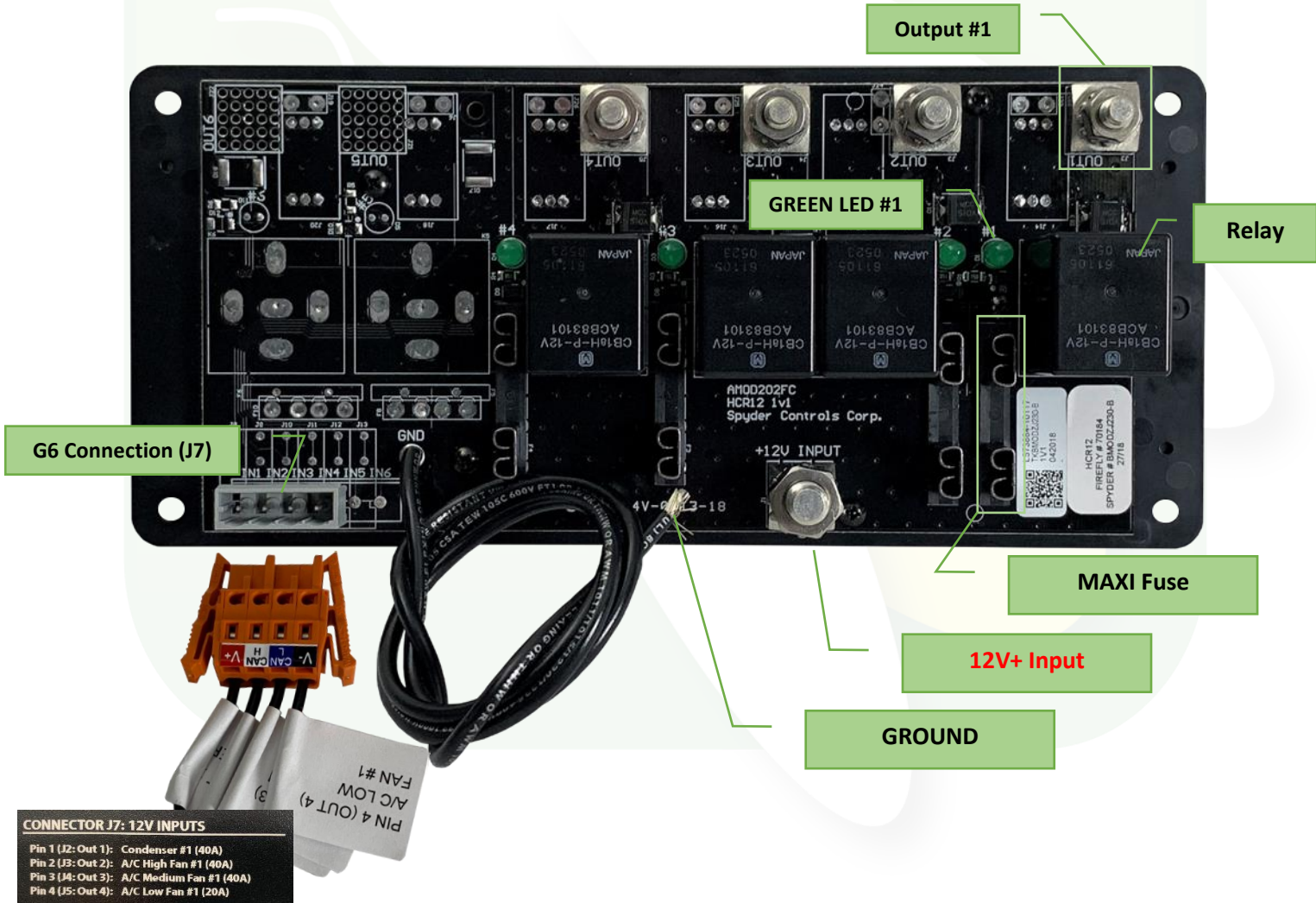
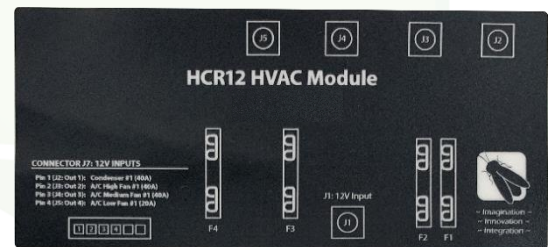



Slide Controls

The G5 HCR-10 Slide Module is used to extend and retract slides and can control up to four individual slides. Reversed polarity between the two spades for each slide is used to switch between extending and retracting the slide. When operating in either mode, you will see an operational LED illuminate while the slide is in motion. If you have the corresponding LED but no movement, check for voltage between the two spades for the slide in question. If you have no LED or Voltage, check for 12V coming to the module. If you verify 12v coming to the module (to the correct inputs), replace the module. *

Each slide will have a Manual Slide Override button that can be used to Extend or Retract a slide in a situation where the network slide control fails to work. Simply press and hold the specific microswitch to engage the slide room's travel.

TESTING A SLIDE MODULE WITH A MULTI-METER

Touch your leads to the extend and retract spades on the slide module as shown in **Figure 1** (Kitchen). When Kitchen Extend is pressed on the switch panel, 12v positive should be sent to the EXT spade. Once retract is pressed, the voltage will flip and 12v positive will be sent to the RET spade. The Operational LED will flash whenever a channel is in operation.

IF A SLIDE IS NOT EXTENDING/RETRACTING:

- Verify that the ignition is turned on.
- Verify that the ignition and power spades have not been swapped.
- Verify that the NET LED is solid green.
- Test the appropriate slide channels with a multi-meter.
- Try to operate the slide with the manual override.
- Replace the slide module if necessary. *

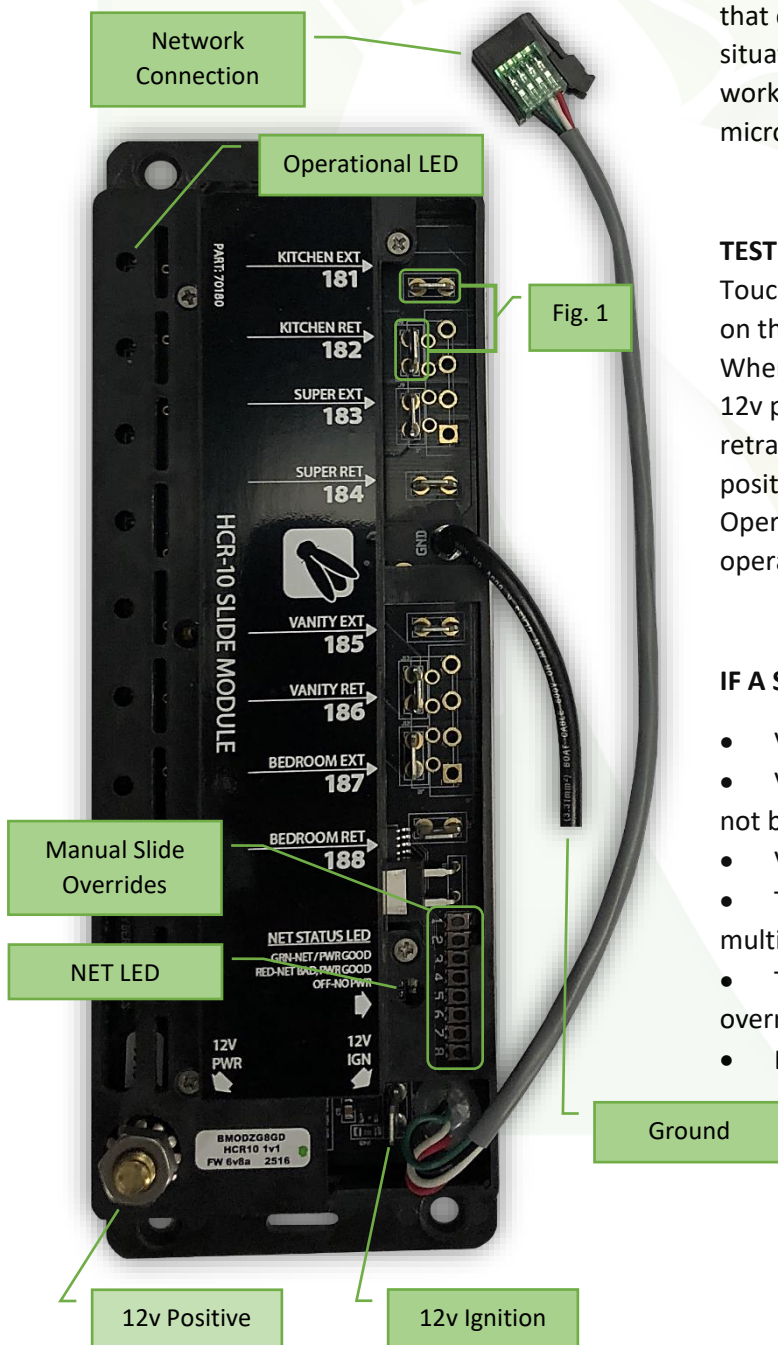

***CONTACT THE COACH MANUFACTURER FOR WARRANTY PROCEDURES.**

G6 PANELS WITH SLIDE OVERRIDES

Some G6 panels will use an internal slide relay card instead of a slide module to control slide room travel. If a slide room fails to travel you will need to check the following:

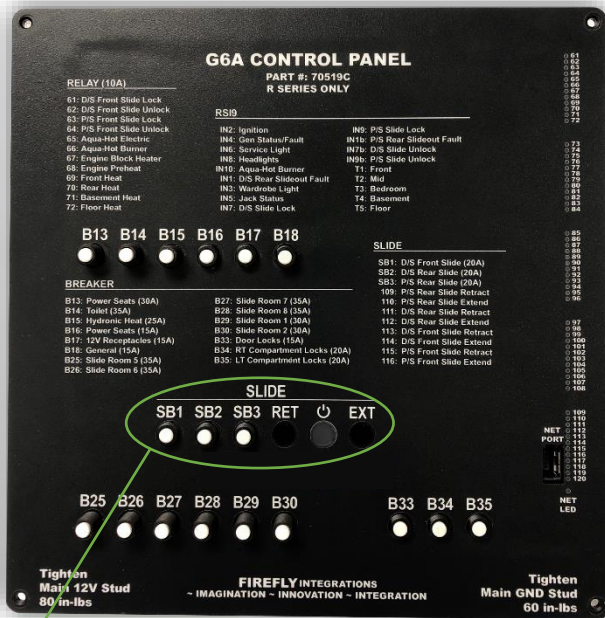

Slide Breakers – Press the white tipped breaker to reset if it has popped out (tripped).

Slide Overrides – Insert a thin object (such as a pencil) to press and hold the internal extend or retract switches to manually run the slide rooms in or out. Notice: All rooms will move at the same time while using the overrides.

- Check the G6 NET LED and switch panel NET LED to ensure that they are illuminated solid green.
- Verify that a white tipped breaker hasn't tripped and reset it if necessary.
- Verify that the circuit LED on the G6 is illuminating green while pressing extend or retract from the switch panel. If a green circuit LED is illuminating, check the output voltage for that circuit on the back of the G6 panel for voltage. If it is not giving at least 12v positive output, replace the slide card. *
- If a circuit LED for a slide will not illuminate, test the switch panel to see if it is defective or try and operate the slide from a different device. If the switch is not defective and a green circuit LED will not illuminate on the G6, replace the G6. *



G5 Shade Modules

These stand-alone modules each operate up to 8 independent window shade motors in a very compact form factor. Built-in H-bridge configuration, over-current protection and ignition/park brake disable inputs are standard features. G5 Shade Control modules can also be used to operate other medium-current motor loads that require reverse polarity type outputs.

Dipswitch Setting

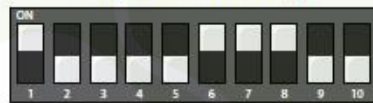

1 Operational LED
 Each channel pair has an operational LED that will illuminate Orange while the shade is moving up or Green while moving down.

2 12V Ignition Input
 While Ignition input is active (12V+) channels 1-4 will not respond to any master commands. All down commands (channels 1-4) require a hold to operate and the command is momentary.



SHADE MODULE A Part #7000050

1A:	P/S Shade UP
1B:	P/S Shade DOWN
2A:	P/S Blind UP
2B:	P/S Blind DOWN
3A:	Entry Shade UP
3B:	Entry Shade DOWN
4A:	Entry Blind UP
4B:	Entry Blind DOWN
5A:	D/S Shade UP
5B:	D/S Shade DOWN
6A:	D/S Blind UP
6B:	D/S Blind DOWN
7A:	Front Shade UP
7B:	Front Shade DOWN
8A:	Front Blind UP
8B:	Front Blind DOWN

CONNECTORS A AND B – 8 PIN 2A Output/Channel

12V+ Power Input

NET LED

Ground

Network Pinout
 Red – 12V positive
 White – Can H
 Green – Can L
 Black - Ground

SHADES HAVE STOPPED WORKING.

A typical coach can have up to 3 different shade modules. You will need to identify which shade module is malfunctioning. Once you locate the shade module in question:

- Verify that the NET LED is solid green.
- Verify that the Ignition and Power spades are connected and haven't been swapped.
- Verify that the dipswitch settings are correct
- Verify that the Molex plugs are connected to the shade module.
- Test the shade module channels with a multimeter to see if they are giving 12v output

TESTING SHADE MODULES WITH A MULTI-METER.

Each shade will operate in pairs. In the example below, when the button to operate P/S Shade Up is pressed, the operational LED for channel 1 will flash and 12V positive will be sent to channel 1A. When the button for P/S Shade Down is pressed, the operational LED will flash, and the polarity will flip to send 12V to channel 1B.

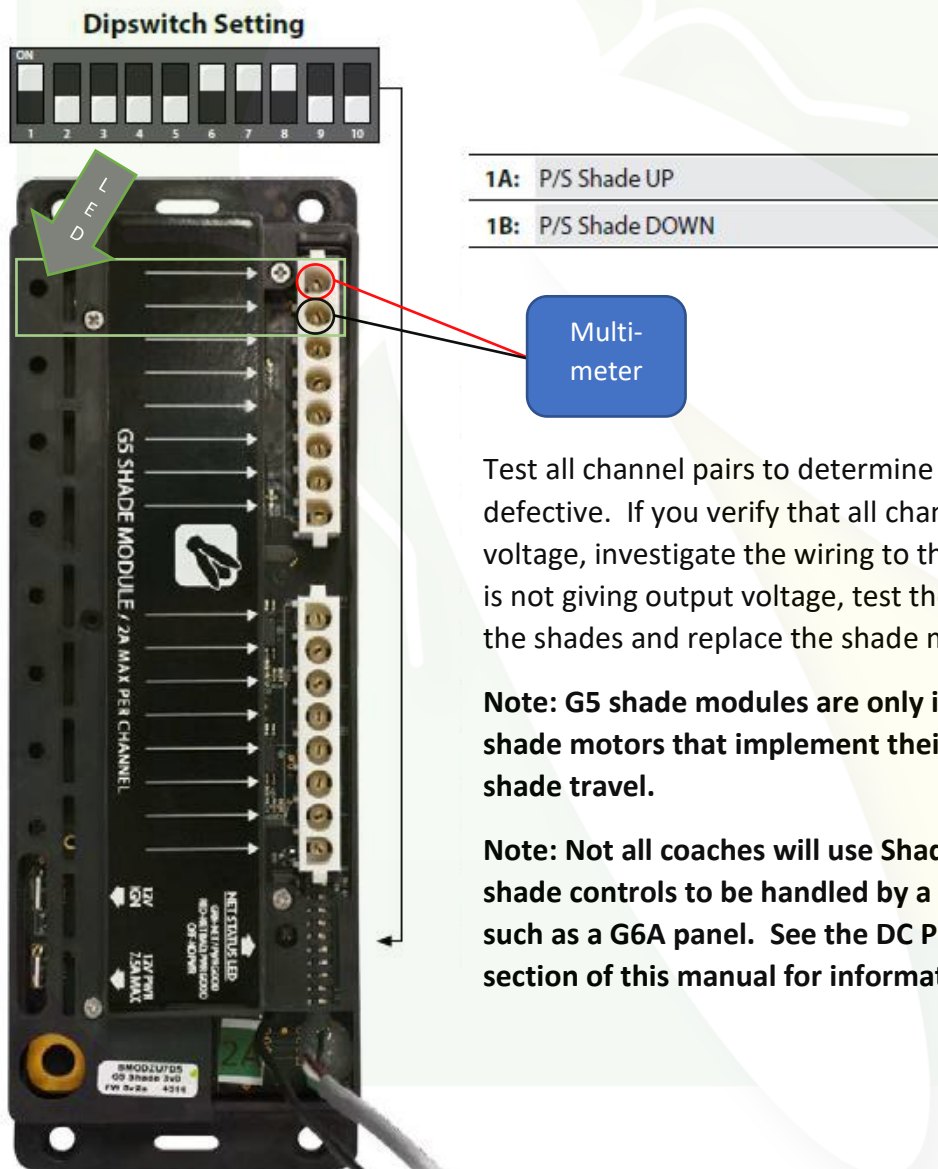

Test all channel pairs to determine if a shade module is defective. If you verify that all channels are giving output voltage, investigate the wiring to the shades. If a shade module is not giving output voltage, test the switch panel that controls the shades and replace the shade module if necessary. *

Note: G5 shade modules are only intended to be used with shade motors that implement their own internal limits for shade travel.

Note: Not all coaches will use Shade modules. It is possible for shade controls to be handled by a power distribution center such as a G6A panel. See the DC Power Distribution Panels section of this manual for information on how to test outputs.



4.3" Touchscreens

The 4.3" monochrome touchscreen integrates familiar hard button functionality with soft button technology to create a powerful and intuitive coach interface.

Pressing a hard button will take you to that particular menu where you will be able to press soft buttons to activate or deactivate circuits.

When a soft button is selected it will display as dark gray. This color change is known as "showing feedback."

All lighting soft buttons work by toggling On/Off with each press. Lighting soft buttons with up/down arrows are dimmable. Simply press and hold these soft buttons to ramp the lights up and down. Other navigation pages may appear at the bottom of the screen that will take you to other menus.

If a touchscreen fails to show feedback, you'll need to check the NET LED status. Use your fingers to gently pry the screen from the corners to release it from the wall plate. To reinstall the screen, simply line it up with the wall plate and gently press to snap it back into place.

Hard Button

Soft Button



NET LED

Wall Plate

NOTE: NEVER START TROUBLESHOOTING UNTIL ALL RELATED NET LED'S ARE CHECKED.

If any NET LED status is anything other than SOLID GREEN please refer to the network troubleshooting page.

IS THE CORRECT FLOORPLAN SELECTED?

Always verify that the floorplan is selected before you begin troubleshooting. If an incorrect floorplan (or no floorplan) is selected, it is likely that the screen won't operate correctly. To select a floorplan, simply press and hold the currently selected floorplan area for 7 seconds and lift your finger. Now choose the correct floorplan from the menu.

A SOFT BUTTON ON THE TOUCHSCREEN WON'T RESPOND.

If you suspect that some part of the Firefly system has malfunctioned (after you have performed a power cycle) click on the Settings button of the touchscreen and check the GUI and LC versions.

Do the GUI and LC numbers match?

It is recommended that the GUI and LC versions match each other for optimal performance. The number to the left of the decimal is the software version and the number to the right of the decimal is the version revision.

You should never have a version discrepancy, such as a GUI 2.X with an LC of 3.X. These are different versions and are not designed to work with each other. The numbers to the right of the decimal point aren't quite as important but could still be causing performance issues if they don't match up perfectly. If the versions don't match up, that means that the wrong hardware was installed by the coach manufacturer. A programmer switch (part # 70011) can be ordered from Firefly Integrations to rectify the situation but this is not covered under warranty.

Does the LC read .255?

If the LC is reading .255, this means that the screen is most likely disconnected from the coach logic controller. Remove the screen from the wall and inspect the network cable at both ends. The blue and white wires are the communication lines. Make sure that these are still connected to the mini plug and have not become loose. It might be possible to give the connector a squeeze with a pair of pliers to fix the connection issue. If it does not help, replace the network cable. *

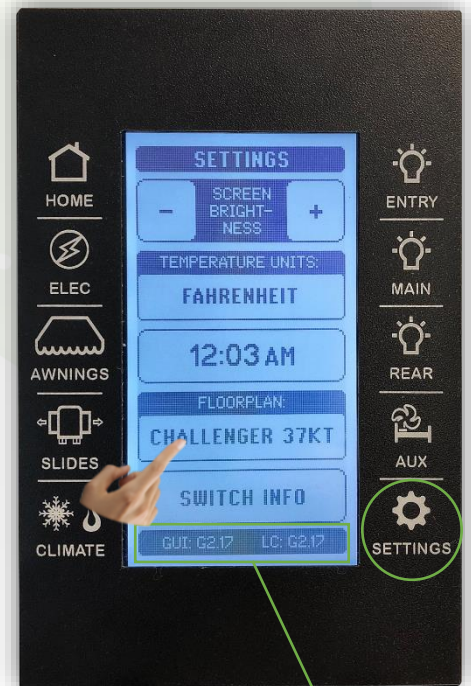

Software Versions

Back of switch





5" Lynx Touchscreens

The 5" Lynx touchscreen uses only soft buttons to control all functions of the system.

The vertical row of navigation buttons at the bottom edge of the screen will transport you from menu to menu with the press of a button.

When a soft button is selected it will display as blue. This color change is known as "showing feedback."

All lighting soft buttons work by toggling On/Off with each press. Lighting soft buttons with up/down arrows are dimmable. Simply press and hold these soft buttons to ramp the lights up and down.

If a touchscreen fails to show feedback, you'll need to check the NET LED status. The Net LED is located on the back of the touchscreen. To remove the screen from the wall, place your fingers along the top edge of the screen and press down while pulling the screen towards you at the same time. This will release the touchscreen from the wall. Be sure not to drop it once it releases from the wall. To reinstall the screen, simply line it up with the wall plate and snap it back into place.





7" Spectrum Touchscreens

The 7" Spectrum touchscreen uses only soft buttons to control all functions of the system.

The row of navigation buttons at the bottom of the screen will transport you from menu to menu with the press of a button.

When a soft button is selected it will display as blue. This color change is known as "showing feedback."

All lighting soft buttons work by toggling On/Off with each press. Lighting soft buttons with up/down arrows are dimmable. Simply press and hold these soft buttons to ramp the lights up and down.

If a touchscreen fails to show feedback, you'll need to check the NET LED status. The Net LED is located on the back of the touchscreen. To remove the screen from the wall, place your fingers along the top edge of the screen and press down while pulling the screen towards you at the same time. This will release the touchscreen from the wall. Be sure not to drop it once it releases from the wall. To reinstall the screen, simply line it up with the wall plate and snap it back into place.



Navigation Buttons

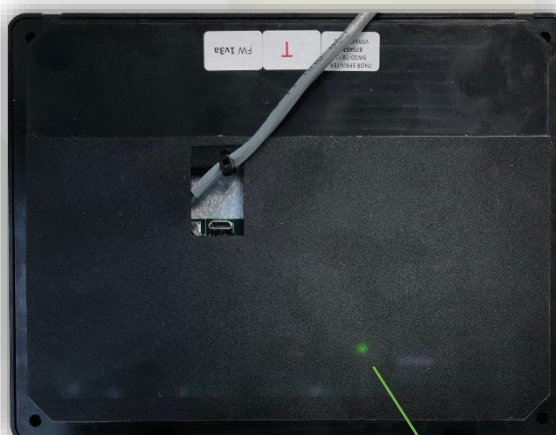
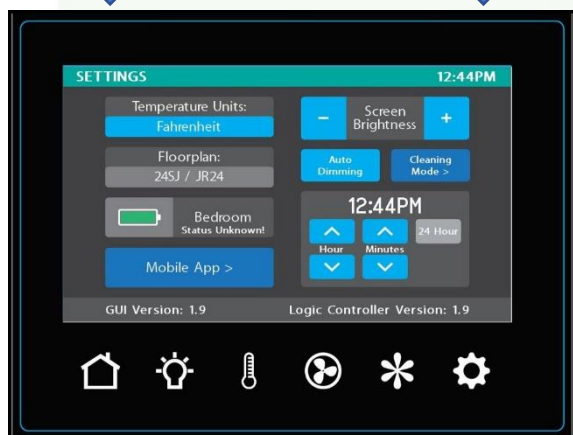

NET LED

IS THE CORRECT FLOORPLAN SELECTED?

Always verify that the floorplan is selected before you begin troubleshooting. If an incorrect floorplan (or no floorplan) is selected, it is likely that the screen won't operate correctly. To select a floorplan, simply press and hold the currently selected floorplan area for 7 seconds and lift your finger. Now choose the correct floorplan from the menu.



A SOFT BUTTON ON THE TOUCHSCREEN WON'T RESPOND.

If you suspect that some part of the Firefly system has malfunctioned (after you have performed a power cycle) click on the Settings button of the touchscreen and check the GUI and LC versions.

Do the GUI and LC numbers match?

It is recommended that the GUI and LC versions match each other for optimal performance. The number to the left of the decimal is the software version and the number to the right of the decimal is the version revision.

You should never have a version discrepancy, such as a GUI 2.X with an LC of 3.X. These are different versions and are not designed to work with each other. The numbers to the right of the decimal point aren't quite as important but could still be causing performance issues if they don't match up perfectly. If the versions don't match up, that means that the wrong hardware was installed by the coach manufacturer. A programmer switch (part # 70011) can be ordered from Firefly Integrations to update the LC version but this is not covered under warranty. The GUI version of a color screen cannot be updated. If the GUI version is reading lower than the LC version, replace the screen. *

Does the LC read .255?

If the LC is reading .255, this means that the screen is most likely disconnected from the coach logic controller. Remove the screen from the wall and inspect the network cable at both ends. The blue and white wires are the communication lines. Make sure that these are still connected to the mini plug and have not become loose. It might be possible to give the connector a squeeze with a pair of pliers to fix the connection issue. If it does not help and all other NET LED's are solid green, replace the network cable. *



7" Lyra Touchscreens

The 7" Lyra touchscreen uses only soft buttons to control all functions of the system.

The vertical row of navigation buttons at the left edge of the screen will transport you from page to page with the press of a button.

When a soft button is selected it will illuminate (blue in this example – Water Pump). This color change is known as Showing Status.

All lighting soft buttons work by toggling On/Off with each press. Lighting soft buttons with up/down arrows are dimmable. Simply press and hold these soft buttons to ramp the lights up and down.

If a touchscreen fails to show feedback, you'll need to check the NET LED status. The Net LED is located on the back of the touchscreen. To remove the screen from the wall, place your fingers along the top edge of the screen and press down while pulling the screen towards you at the same time. This will release the touchscreen from the wall. Be sure not to drop it once it releases from the wall. To reinstall the screen, simply line it up with the wall plate and snap it back into place.

If a screen software update is necessary, it may be possible to perform the update using a flash drive and the USB port located on the back of the screen. Note: USB Bootloader Version 2v0 or higher is required to perform an update.



Navigation Buttons along left edge.

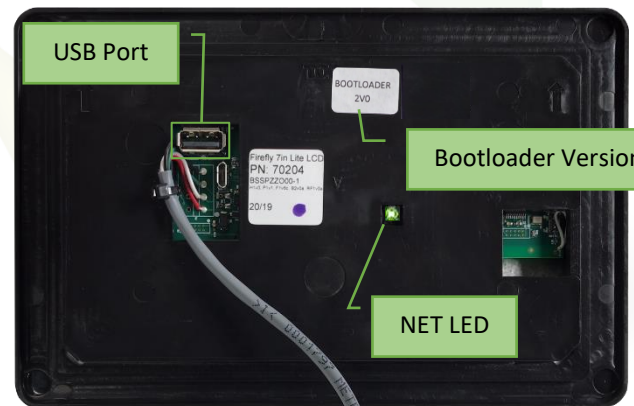

Bootloader Version

NET LED



10" Polaris Touchscreens

The 10" Polaris touchscreen uses only soft buttons to control all functions of the system.

The Vertical row of navigation buttons at the left edge of the screen will transport you from menu to menu with the press of a button.

When a soft button is selected it will illuminate (blue in this example – Aqua-Hot Burner). This color change is known as Showing Status.

All lighting soft buttons work by toggling On/Off with each press. Lighting soft buttons with up/down arrows are dimmable. Simply press and hold these soft buttons to ramp the lights up and down.

If a touchscreen fails to show status, you'll need to check the NET LED status. The Net LED is located on the back of the touchscreen. To remove the screen from the wall, place your fingers along the top edge of the screen and press down while pulling the screen towards you at the same time. This will release the touchscreen from the wall. Be sure not to drop it once it releases from the wall. To reinstall the screen, simply line it up with the wall plate and snap it back into place.

If a screen software update is necessary, it may be possible to perform the update using a flash drive and the USB port located on the back of the screen. Note: USB Bootloader Version 2v0 or higher is required to perform an update.

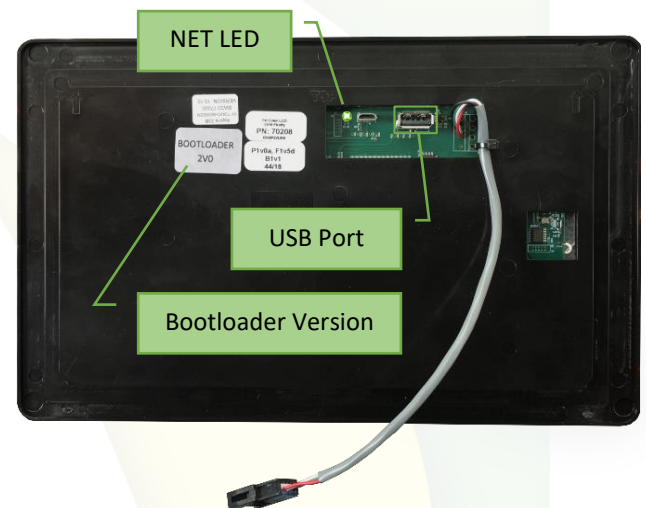



10" Orion Touchscreens

Vegatouch is a state-of-the-art coach control interface which allows the user to easily monitor all control all major systems in the coach.

Vegatouch screens come in 10" and 7" models.

Many of our Vegatouch systems integrate with Crestron to incorporate A/V control, as well as mobile coach control with smart devices.



VERIFY THE CURRENTLY SELECTED FLOORPLAN AND OPTIONS BEFORE TROUBLESHOOTING.

Press and hold the Question Mark for 7 seconds to enter the Vegatouch software versions screen.

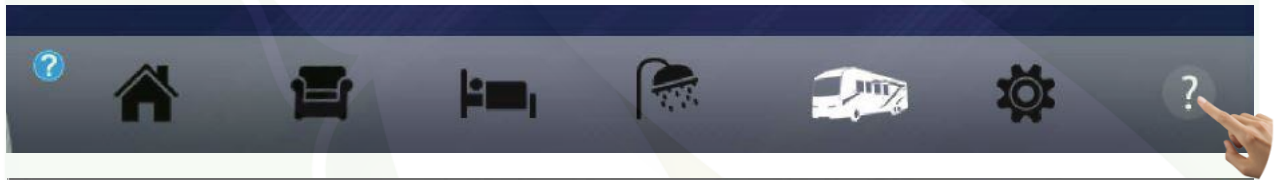

Current Tab

Current Tab

Main

Feedback

Close

GUI Version: VegaTouch_ Orion10_1v2v5
 Software: 1.2.5
 Firmware: 1.2.2
 OS Version: 1.1.1
 Crestron Version: 1v3
 Outboard LC Version: 33
 Copyright 2017 Firefly Integrations

M

Software Versions

Tap just inside of each corner on the Vegatouch logo ★ (one at a time) to make hidden navigation tabs appear on the left side of the screen.

1 Inverters - Displays information from your Inverters.

The screenshot shows a control interface with a sidebar on the left containing buttons for Main, Feedback, Power, Options, Other, and Uploader. A green arrow labeled "Prev. Hidden" points to the "Options" button. The main area is divided into three sections: "Inverter 1" (callout 1) showing Inverter Model and Firmware Version; "Inverter 2" showing Inverter Model and Firmware Version; and "Generator" (callout 2) showing Run Time Hours (0) and a "Reset Gen Run Time Hours to 0." link. On the right, the "AGS" section (callout 3) contains several adjustable parameters: Volt-Based Start Time (120), Volt-Based Shutoff Voltage (13.50), Volt-Based Shutoff Time (120), Minimum Run Time (15), Maximum Run Time (12), Number of Retries to Start (5), and Time Between Retries (40). A "Close" button is at the bottom left.

2 Generator - Tap +/- to adjust the Generator hours saved to the system or tap Reset to set the hours to zero.

3 AGS - Tap +/- to set your desired AGS values.

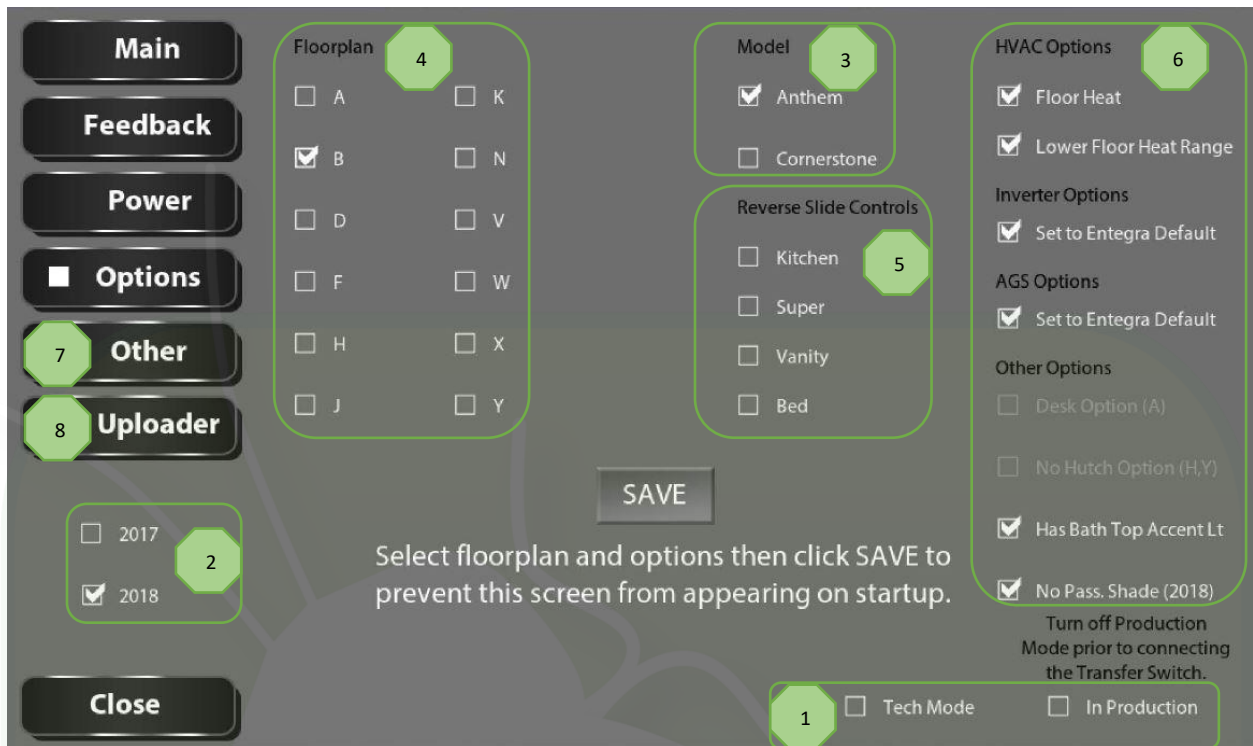

- 1 Mode Selector- Choose tech mode for faster operation. Choose production mode before you're finished working on the coach.
- 2 Year Selector- Choose the desired year (version) of Vegatouch for the coach.
- 3 Model Selector- Choose Anthem or Cornerstone.
- 4 Floorplan- Choose the appropriate coach floorplan.
- 5 Reverse Slide Controls- Check the box if you need a slide to reverse direction.
- 6 Misc. Options- It is recommended to select Entegra Defaults for Inverter and AGS defaults.
- 7 The "Other" tab contains tools for troubleshooting screen hardware and software, generally in a bench environment.
- 8 The "Uploader" tab will only be used when replacing the Vegatouch screen with a newer version. Please see the Vegatouch Replacement Guide for more information.

The Feedback screen will show the status of every circuit in the system. The text will display white when on and black when off.

The HVAC and Tanks information will always be displayed in white.

<p>Main</p> <p>Feedback</p> <p>Transfer Switch Brake Ignition Generator</p> <p>Reboot Screen</p> <p>Close</p>	<p>DC Dim</p> <p>1: AquaHot LR fan 2: AquaHot BR fan 3: AquaHot Bmnt 4: 5: AquaHot Floor 6: AquaHot Diesel 7: AquaHot Elect 8: Engine Preheat 9: Motion Sensor 10: Security Lt DS 11: Security Lt ODS 12: 13: Bath Ceiling Lt 14: Bath Lav Lt 15: Bath Upper Lt 16: Bath Base Lt 17: Bed Ceiling Lt 18: Bed OH Lt 19: Bed Accent Lt 20: Bed Vanity Lt 21: Courtesy Lt 22: Stool Ceiling Lt 23: Stool Accent Lt 24: 25: LR Ceiling Lt 26: LR Upper Lt 27: LR Base Lt 28: LR Edge Lt 29: LR Misc A Lt 30: LR Misc B Lt 31: LR Misc C Lt</p>	<p>32: LR Misc D Lt 33: Dinette Lt 34 Sink Lt 35: Midship Lt 36: Ent.Center Lt 37: Water Pump 38: Under Slide Lt 39: ODS Awning Lt 40: DS Awning Lt 41 42 43 44 45 46 47 48</p>	<p>85: Cargo Door Lock 86: Entry Door Lock 87: Gen Start 88: Cargo Dr Unlock 89: Entry Dr Unlock 90: Gen Stop 91: RR Awning Ext 92: RR Awning Ret 93: RR Awning Stop</p>	<p>94: FR Awning Ext 95: FR Awning Ret 96: FR Awning Stop 97: A/C Comp 1 98: High Fan 1 99: Low Fan 1 100: Heat Pump 1 101: A/C Comp 2 102: High Fan 2 103: Low Fan 2 104: Heat Pump 2 105: A/C Comp 3 106: High Fan 3 107: Low Fan 3 108: Heat Pump 3 109: Entry Awning Ext 110: Entry Awning Ret 111: Cargo Lt 112: Satellite Dome 113: Entry Ceiling Lt 114: Porch Lt 115 116 117 118 119 120 121 122 123 124</p>	<p>181: ODS Fr Sld Ext 182: ODS Fr Sld Ret 183: DS Fr Sld Ext 184: DS Fr Sld Ret 185: ODS Rr Sld Ext 186: ODS Rr Sld Ret 187: DS Rr Sld Ext 188: DS Rr Sld Ret</p>	<p>Temps</p> <p>1: front 72° 2: bed 74° 3: base 48° 4: 65 5: floor 5 6: mid 71° 20: ext 43°</p> <p>24 clock 0 Sch One 630 Sch Two 2100 Time Prd 1</p> <p>Lng1 AC 76 Lng2 AC 76 Lng Ht 64</p> <p>Bd AC 88 Bd Ht 53 Base 48 Floor 84</p> <p>AC-run 0</p> <p>Tanks</p> <p>1: fresh 65 2: black 27 3: grey1 50 19: grey2 30</p>
	<p>selectShorePower 30</p>					

PRESS CLOSE TO EXIT THE SETUP SCREENS AND RETURN TO VEGATOUGH HOME.

VEGATOUGH HAS LOST COMMUNICATION (MESSAGE CENTER NOTIFICATION).

Locate the battery disconnect switch near your entry door. Use that switch to power cycle the coach (turn 12V power off for 10 seconds and turn it back on). Note, the lights will go out in your coach while performing the power cycle.

If the error message persists after the system has booted back up, check the NET LED status for each G6. If they are displaying anything other than solid green, see the Network Troubleshooting page.

If the LED's are solid green, check the CAN cable on the back of the Vegatouch to ensure that no wires are loose. Replace the cable if necessary. *

If this error happens often, contact Firefly Integrations for additional support.

AUDIBLE ALARMS HAVE STOPPED FUNCTIONING.

From the Message Center, check to make sure that the Speaker Icon (Chime) hasn't been turned off. Also, it is possible that the alarm has been muted for certain hours. Verify that the "Mute Alarm Chime Between" box is unchecked.

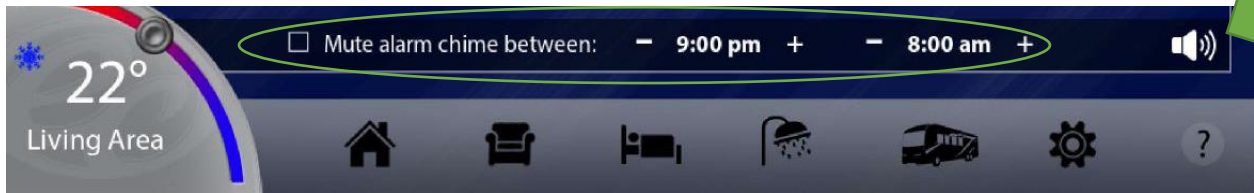

AUDIBLE ALARMS HAVE STOPPED FUNCTIONING...CONTINUED.

Verify the speaker is connected to the Vegatouch (back side of the screen). Also verify that the wires are connected to the speaker.

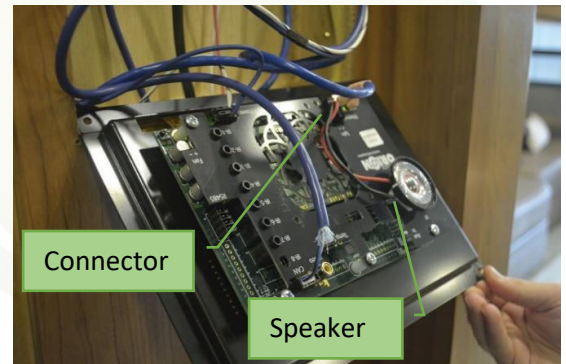

THE TIME IS INCORRECT ON VEGATOUCH (JAYCO).

The Xite radio probably needs to be connected to the coach router. From the Xite, click on Menu and then Vegatouch. You should now see a WIFI symbol that you can click to enter the router's password. The password is located on the router's Firefly label.

A/V NO LONGER FUNCTIONS ON VEGATOUCH.

Press and hold the question mark in the lower right-hand corner of the Vegatouch panel for 10 seconds and a software versions list will appear on the screen. Does the Outboard LC version say Lost Connection?

- Yes – Power cycle the RMC3 processor and router (SEE THE NEXT PAGE).
- No – Check AV wiring. Diagrams are available from Firefly Integrations.

THE CRESTRON APP WON'T CONNECT TO THE COACH.

It is important to note that if you are unable to connect to the coach from the Crestron mobile app, you need to verify the following:

- You are connected to the coach's WIFI signal.
- You are using the most current Crestron App.
- You are using the correct Crestron App for your device.
(IPAD – CRESTRON MOBILE PRO G) (IPHONE – CRESTRON MOBILE PRO) (ANDROID)
- You are not using the Free Crestron app to operate a coach.
- The operating system on your device is up to date.
- Your app has been setup according to the instruction manual located at www.vegatouch.com.

Press and hold the question mark in the lower right-hand corner of the Vegatouch panel for 10 seconds and a software versions list will appear on the screen. Does the Outboard LC version say Lost Connection?

- Yes – Power cycle the RMC3 processor and router (SEE THE NEXT PAGE).
- No – Contact Firefly Integrations for additional support.

POWER CYCLE THE RMC3 PROCESSOR AND ROUTER.

- REMOVE THE RED CABLE FROM THE RMC3 FOR 10 SECONDS
- UNPLUG THE ROUTER FOR 10 SECONDS
- PLUG BOTH CABLES BACK IN AND ALLOW 2 MINUTES FOR THE SYSTEM TO REBOOT.



VegaTouch Screen Replacement

Check Current Settings

1. On your current screen, press and hold the Question mark for 7 seconds (3A) to enter the Service Page.
2. Tap inside each corner of the VegaTouch image (one at a time) to show hidden options (4A). Tap the Options tab to view your settings (5A).
3. Options Page: Write down all checked settings.

Floorplan _____ Reverse Slide _____ HVAC _____

Inverter and AGS (Set to Default)

Other _____

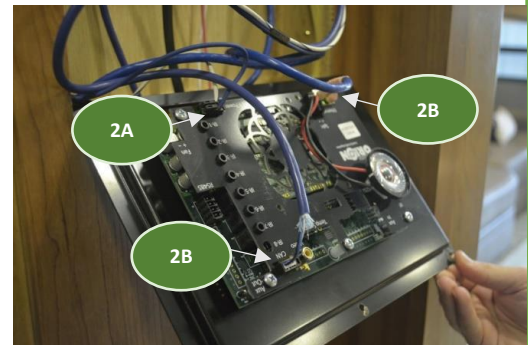
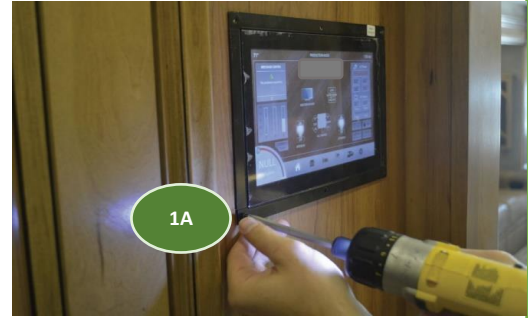

Removing the Touchscreen

1. Remove magnetic bezel and unscrew touchscreen from the wall using square bit/large philips bit (1A).
2. Remove the power cable (2A) from the back of the touchscreen. Next, remove the CAN and Ethernet cables (2B).
3. Reverse this procedure to plug the cables into the new screen.

New Touchscreen Configuration

1. Press and hold the Question mark for 7 seconds (3A).
2. Tap inside each corner of the VegaTouch image to show hidden options (4A).
3. Go to Options Page (5A) and check settings you have saved from the old screen.
4. Go to Uploader Page (6A) and select **Controller App** (7A).
5. Hit the down arrow to select **Config Instance 1** and click Upload (8A).
6. Once the uploader has finished, the screen has successfully been configured (9A).
7. Cycle 12-volt power to complete the installation.

IMPORTANT!

Please ensure **CONTROLLER APP** is selected in New Touchscreen Configuration Utility Step 4. Uploading any other option may cause damage to the system.

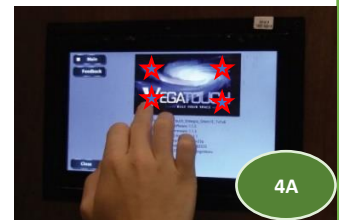
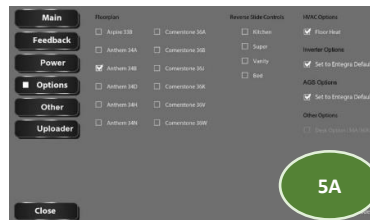
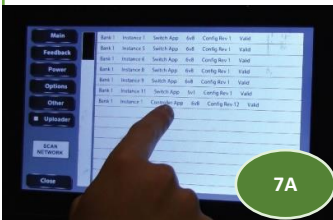

NOTE: Do not be concerned if your installation stops at 99% and times out. Simply cycle the power (New Touchscreen Configuration - Step 7) to complete the installation.

AGS Setup

Press and hold the Auto Gen button from the Vegatouch Settings screen to enter the AGS Settings screen.



Tap the boxes to enable your desired AGS triggers. If you enable Quiet Time, tap the +/- keys to set the quiet time hours.

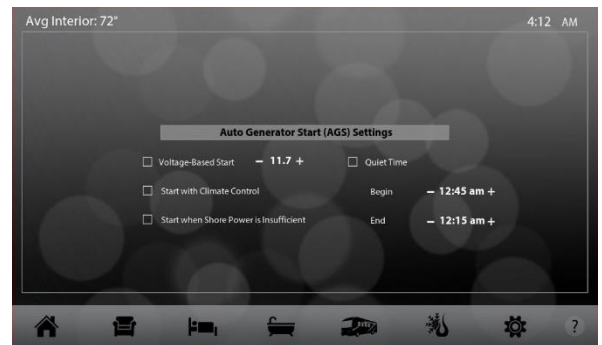



Vegatouch Eclipse Module

Vegatouch Eclipse is a wireless control module that easily connects to any Android or iOS device to give total control to many electrical, electronic and mechanical systems in your coach. Pair any device with the coach's built-in interface to monitor and control every component.

To install, simply connect a network cable to the Net Port on this device.

See the next page for setup instructions.

Troubleshooting:

I CAN'T CONNECT TO ECLIPSE WITH MY SMARTPHONE/TABLET.

Make sure that Bluetooth is enabled on your smartphone/tablet and follow the setup instructions on the next page. Always make sure that you are using the most current version of the Eclipse app. Update the app if necessary.

WHEN I TRY TO CONNECT, THE SCREEN SAYS "SYNCING" AND NOTHING HAPPENS (OR SAYS OUT OF RANGE).

Click on the settings page of your touchscreen and verify that your coach's floorplan is selected. If the floorplan is blank, Eclipse won't be able to connect.

The network cable could also be faulty. Inspect the cable at both ends and replace it if necessary. If the cabling and setup seem to be correct, contact Technical Support.

CAN I ADD AN AFTERMARKET ECLIPSE MODULE TO A COACH?

Contact Firefly Integrations for more information about upgrading to Eclipse.

BLINKING LED

A blinking green NET LED on this module is fully functional and does not indicate that the module has network connectivity issues.

Reset the Eclipse password back to default (777777) by inserting a thin object, such as a toothpick, into the small hole on the front of the module and pressing the internal reset button for 5 seconds.





Eclipse Installation

Contents of the Kit

Coaches with a color touchscreen will receive an Eclipse module, a 12" network cable, a programmer switch and a replacement color touchscreen. Please ensure that you have received all of the required components before proceeding with the installation.

Step 1 – Changing the color screen

Go to the color touchscreen that is mounted in your coach. Place your fingers along the top edge of the screen and press down while pulling the screen towards you at the same time. This will release the touchscreen from the wall. Be sure not to drop it once it releases from the wall.

Remove the network cable from the back of the screen. Note: you'll need to depress a little tab on the side of the connector to release it from the screen.

Once the screen has been removed, plug the network cable into the new touchscreen. Now, snap the new screen onto the wall mount. If the new screen fails to snap into place, ensure that the screen does not have an extra wall plate attached to it.

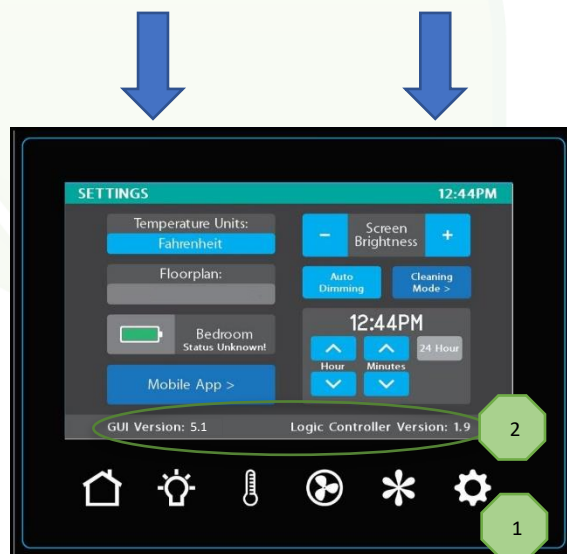

Step 2 – Use the programmer switch to update the Logic Controller

Press the lower right gear icon (Figure 1) to access the settings page. Check the GUI and Logic Controller (LC) versions on the bottom of the screen (Figure 2). The GUI version should now match the version that is printed on the programmer switch label. The LC version will read a lower version than what is on the label. This is correct.

Plug the programmer switch into the Net Port on the front of the G6 panel. LED's will now light up beside some of the 4 buttons on the programmer switch. Press and release button A to begin the upload process. The LED beside Button A will flash red/green for a few seconds while it is uploading and will then turn solid green once the upload has completed. After it has turned solid green, continue this process in alphabetical order until all of the lighted buttons have been uploaded.

Remove the programmer switch from the net port and power cycle your coach (12v). Once it boots back up, verify that your GUI and LC versions now match what is on the programmer switch label.



Step 3 – Install the Eclipse Module

Locate any of the network drop taps (Figure 3) to access an open network port. The Eclipse installation and programmer switch updates can be performed from any open network port.

Locate the 12" network cable that shipped with your Eclipse upgrade kit. Plug one end of the network cable into the network port of the Eclipse module and the other end into any empty network port. Finally, screw down the module to a solid surface. For best results, avoid mounting the module behind metal or near other wiring if possible.

If you are unable to locate an empty network port, please contact technical support for a Network Wiring Diagram specific to your floorplan. If installing to an empty network port isn't an option, move on to Step 4.

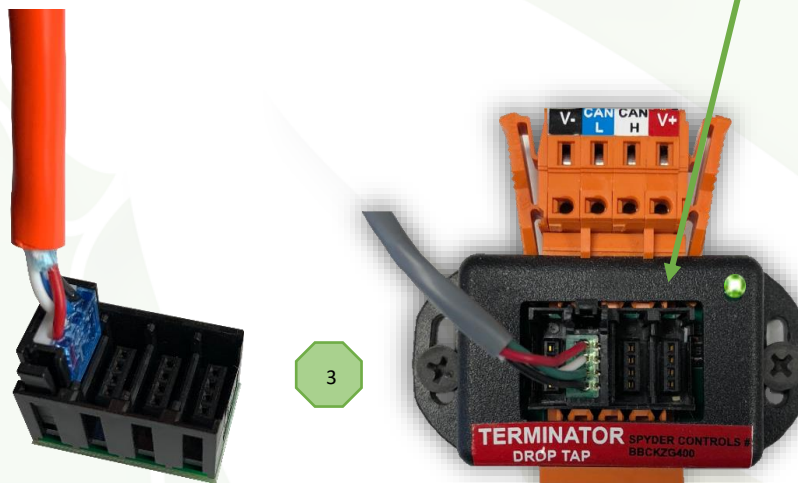

Step 4 – Installing the Eclipse Module behind the G6 Panel.

For best results, the module should be mounted as far away from your G6 panel and other wiring as possible.

Remove the 4 screws that are holding the G6 panel to the wall. Once loose, gently pull the G6 panel from the wall in order to expose the back side of it.

Locate the 12" network cable that shipped with your Eclipse upgrade kit. Plug one end of the network cable into the network port of the Eclipse module and the other end into any empty network port on the RSI card.



Screw down the Eclipse module to a solid surface. Be sure not to screw into any of the wiring.

Screw the G6 back into the wall.

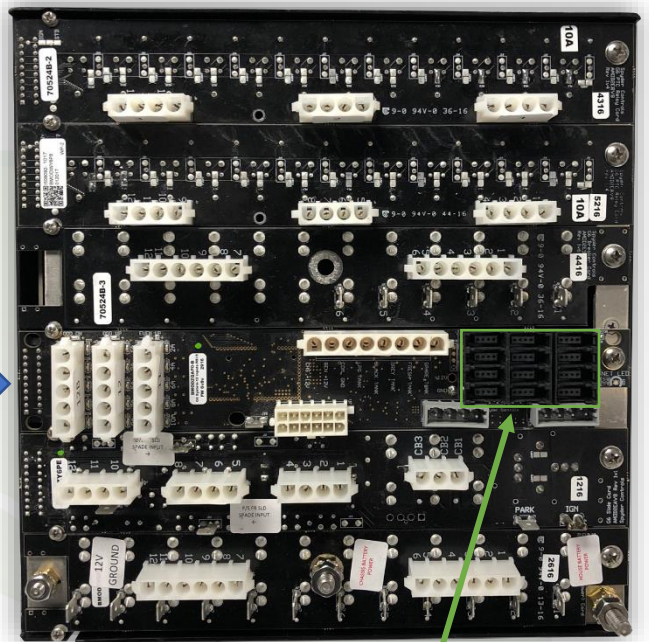



Eclipse Setup

Notice: Make sure that Bluetooth is turned ON in your smart device settings before proceeding.

Locate the Login Information:

The login information can be found by clicking on the Mobile App button on the settings page of the touchscreen or from the Eclipse module's label.



Download:

Download Vegatouch Eclipse from the Google Play store or the App Store. Once the download has finished, install the app and open it.

1

Press and Hold the logo for 7 seconds to switch between Mira and Eclipse if necessary.

Setup:

Tap SCAN to find the Eclipse Module's signal. After scanning, any Eclipse Module in your area will appear on the screen (the list is scrollable). Tap the ID # that matches the one for your Eclipse. Enter the PIN number from the Eclipse label and press AUTHENTICATE to connect to the system. You will need to reset the pin number once prompted. Enter your custom number and tap SET PIN to save.

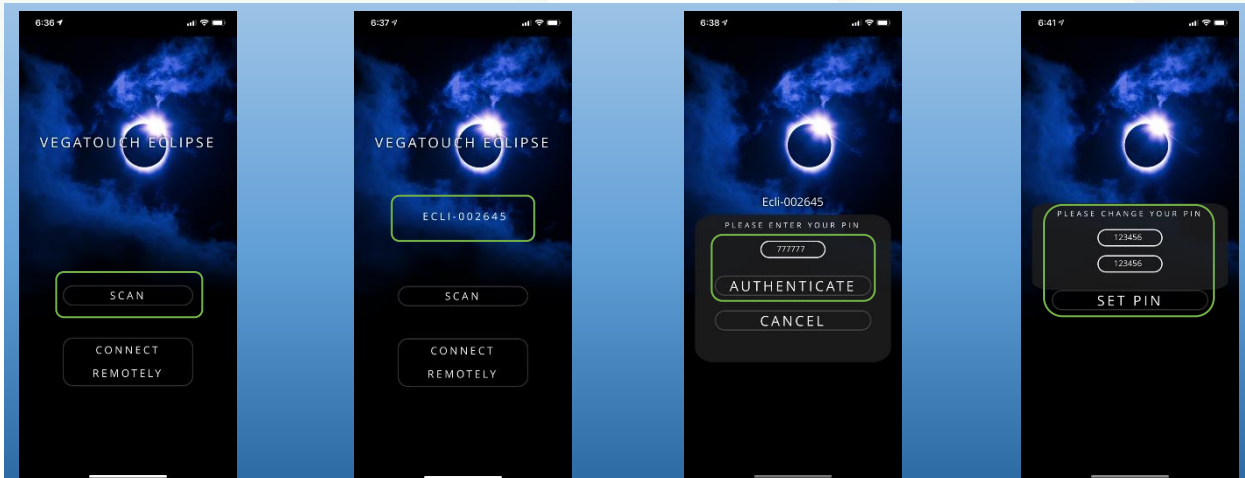

Notice: iOS Setup Tips

Turn on Bluetooth to allow Vegatouch Eclipse to connect to Accessories.

If you do not have Bluetooth turned ON in your iOS settings, you will see this screen. Do not click OK, you must click SETTINGS. Your Bluetooth Settings page will now appear and you should turn Bluetooth ON.

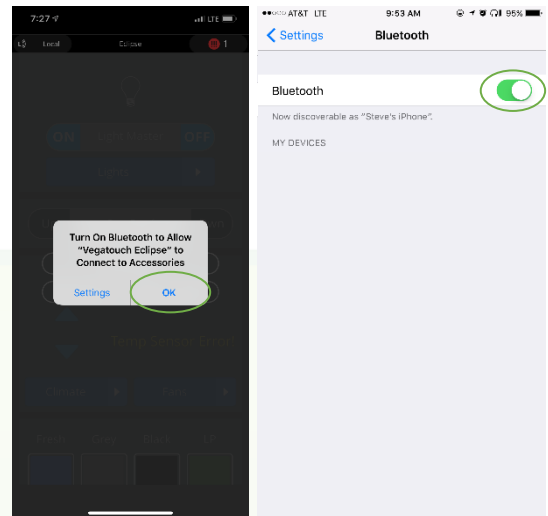

Notice: Android Setup Tips

Allow Vegatouch Eclipse to access this device's location.

Eclipse will need to be allowed access to your location. Tap ALLOW when you see this screen. If you do not tap allow, the module will not be found in the scan.

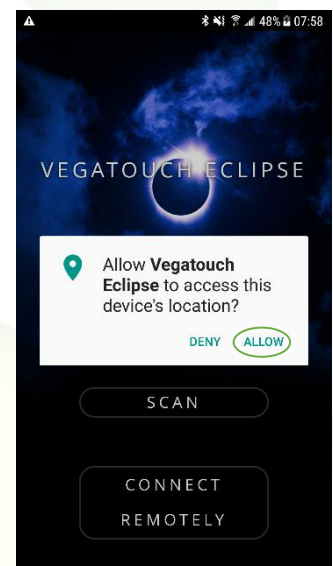

App Settings:

Access the App Settings page by tapping the triangle (at the bottom of the screen) to expose the Settings button. Tap the gear to visit the settings page.

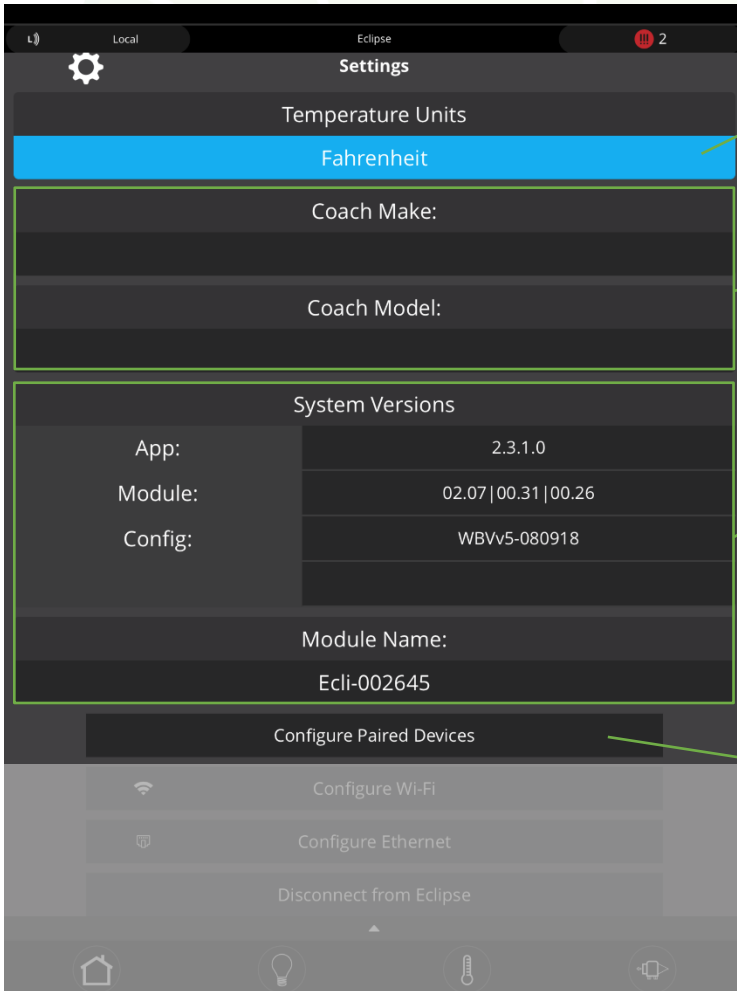
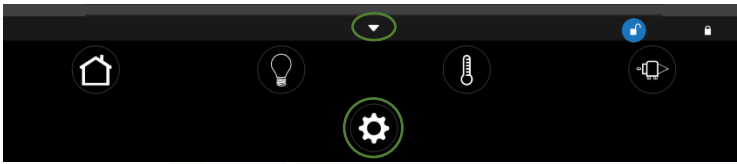

Tap to Temperature Units selection to choose between Fahrenheit and Celsius.

Make and Model of your coach.

System Information and Eclipse Name.

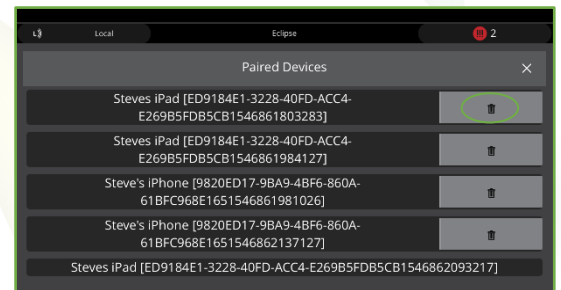

Configure Paired Devices:

Tap to display a list of devices which are currently paired to Eclipse. Tap the trash can icon to completely remove a specific device from memory. Once removed, this device will no longer have remote access to the system. Note, you cannot remove the device that you are currently using.

Configure Wi-Fi:

- 1 Tap the available Wi-Fi network that you would like to connect to. If your network is not listed, tap Refresh to scan again.
- 2 Type in the Security Key and tap Connect to join the network.
- 3 A white Ball and Socket will display once connection has been made. A Green Checkmark signifies that the password has been stored in memory.
- 4 Visit the Saved Networks page to quickly connect to previously used networks.

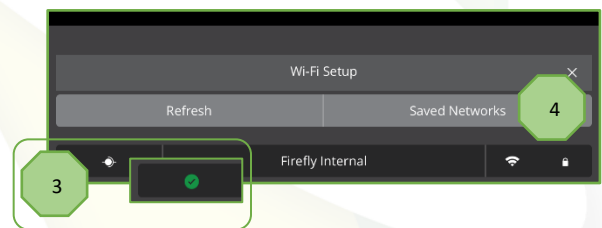
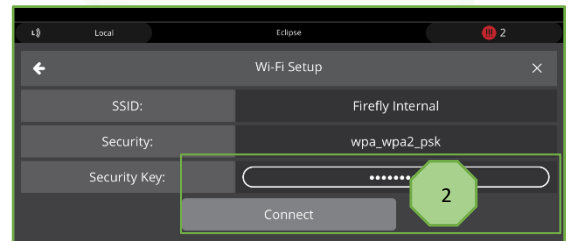
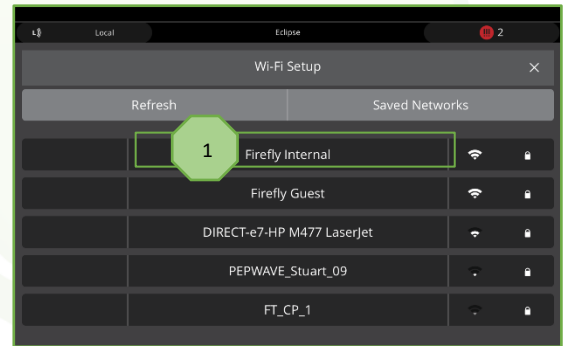
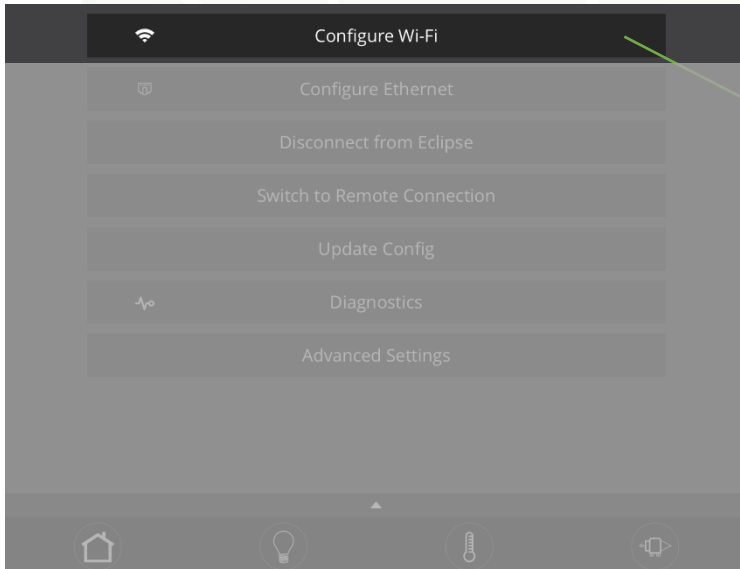

Configure Ethernet:

- 1 Tap Configure Ethernet if you'd prefer to use your Eclipse with a wired ethernet connection. Tap the Prefer Ethernet checkmark if you'd prefer to use an ethernet connection exclusively.

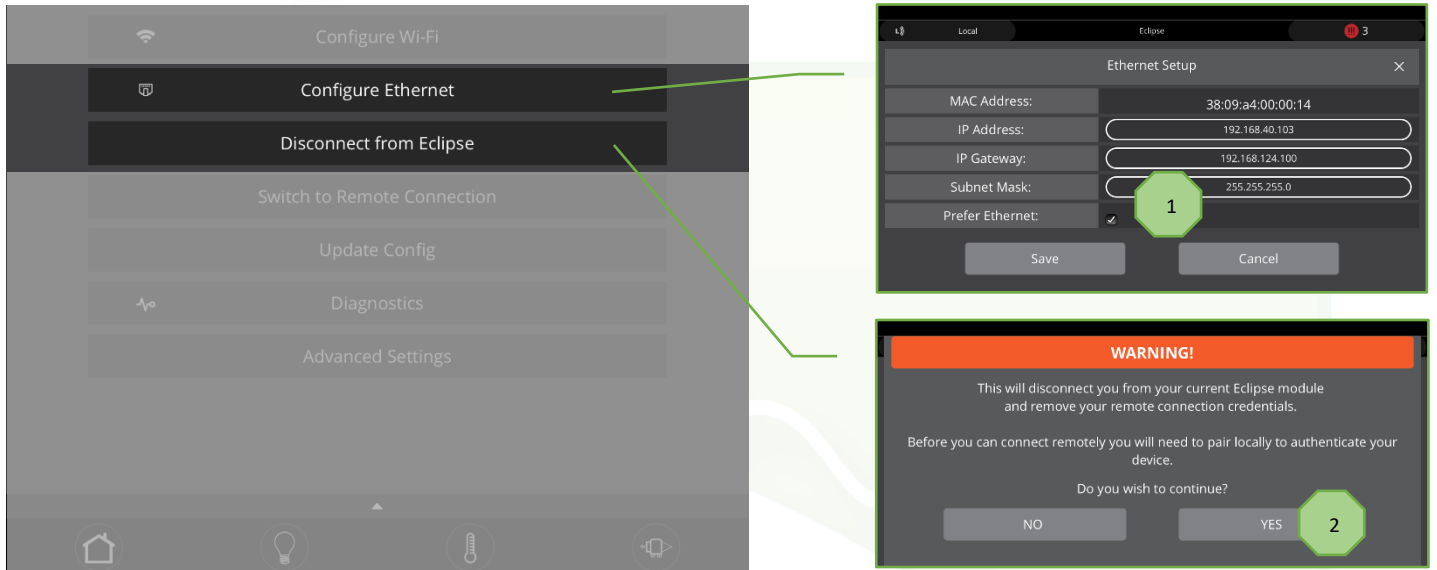

Disconnect from Eclipse:

- 2 Tap YES if you'd like to disconnect from Eclipse. Note, before you can connect remotely, you'll need to pair locally to authenticate your device.

Switch to Remote Connection:

1 Tap to switch between a Local and Remote location. The Local/Remote switch page can also be reached by tapping Local or Remote on the top bar.

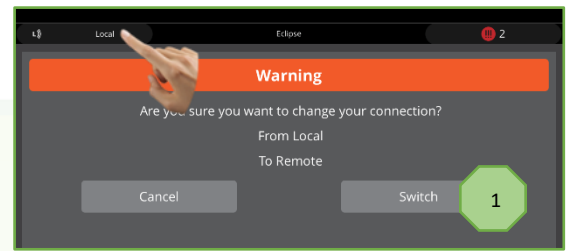
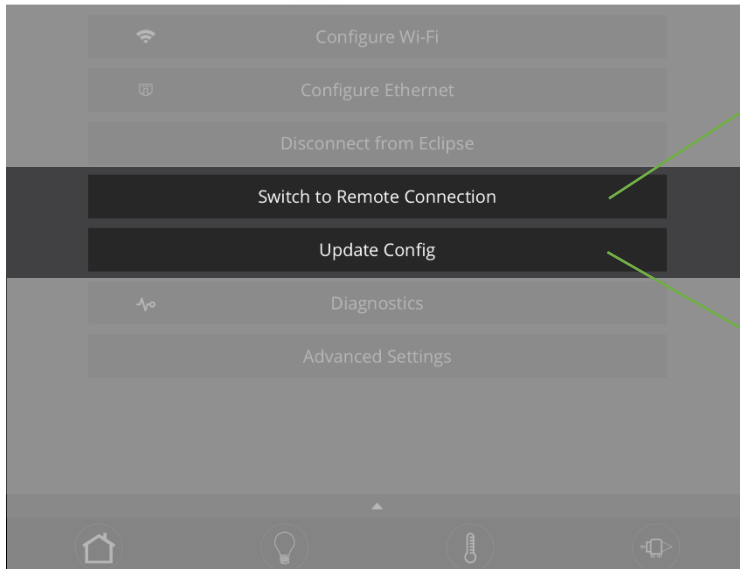

Tap to update the config from the cloud.

Diagnostics:

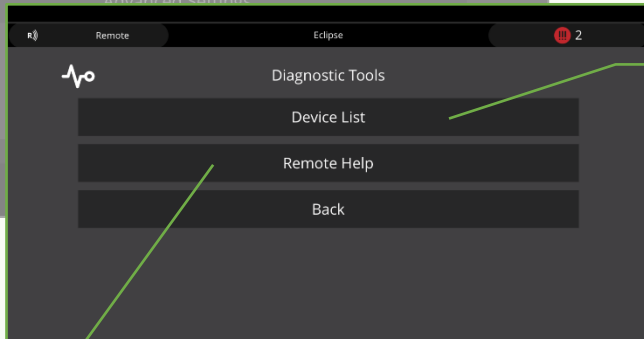
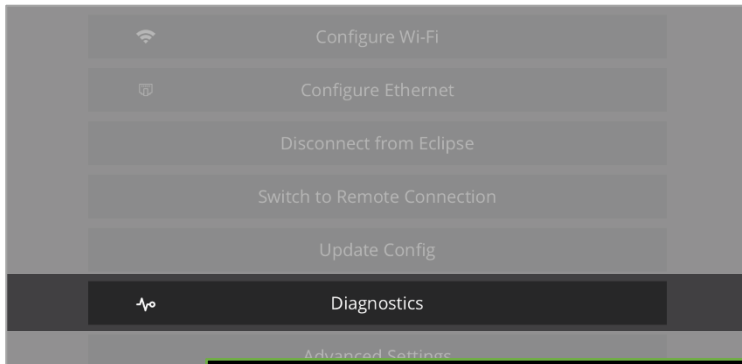

Tap to display a list of currently connected devices.

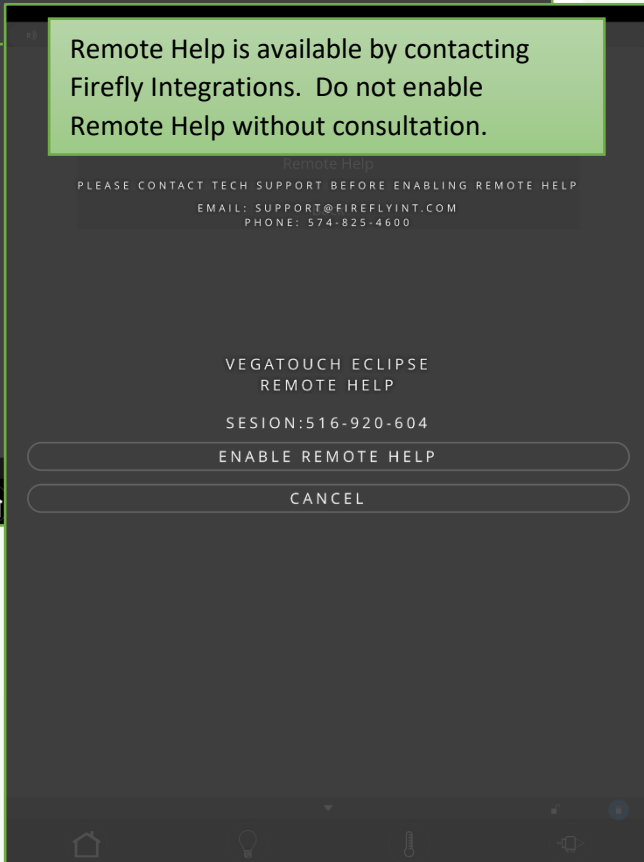

Advanced Settings:

1 Tap to set a custom pin number.

2 Tap to completely reset the device. A warning page will appear which will require you to confirm the action.

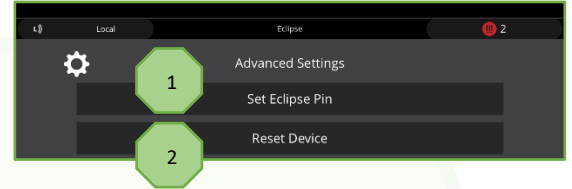
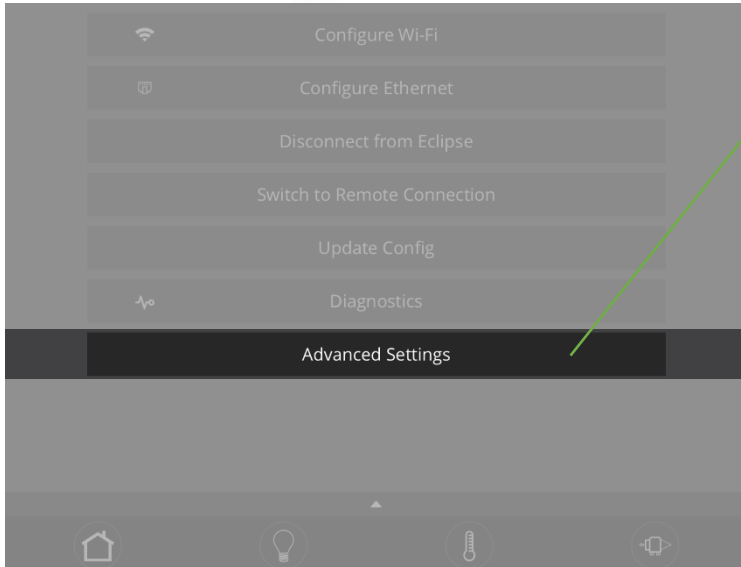



Vegatouch Mira Modules

Vegatouch Mira is a wireless control module that easily connects to any Android or iOS device to give total control to many electrical, electronic and mechanical systems in your coach. Pair any device with the coach's built-in interface to monitor and control every component.

It is important to note that there is no external NET LED on this device. To install, simply connect a network cable to the Net Port on this device.

See the next page for setup instructions.

Troubleshooting:

I CAN'T CONNECT TO MIRA WITH MY SMARTPHONE/TABLET.

Make sure that Bluetooth is enabled on your smartphone/tablet and follow the setup instructions on the next page. Always make sure that you are using the most current version of the Mira app. Update the app if necessary.

WHEN I TRY TO CONNECT, THE SCREEN SAYS "SYNCING" AND NOTHING HAPPENS (OR SAYS OUT OF RANGE).

Click on the settings page of your touchscreen and verify that your coach's floorplan is selected. If the floorplan is blank, Mira won't be able to connect.

The network cable could also be faulty. Inspect the cable at both ends and replace it if necessary. If the cabling and setup seem to be correct, contact Firefly Integrations about possibly replacing the Mira module.

CAN I ADD AN AFTERMARKET MIRA MODULE TO A COACH?

Contact Firefly Integrations for more information about upgrading to Mira.

Regarding 2nd Generation Mira Modules:

A blinking green NET LED on this module is fully functional and does not indicate that the module has network connectivity issues.

Reset the Mira's password back to default (777777) by inserting a thin object, such as a toothpick, into the small hole on the front of the module and pressing the internal reset button for 5 seconds.

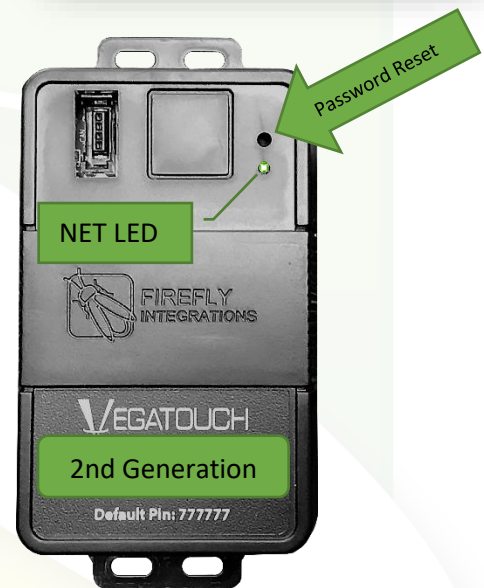
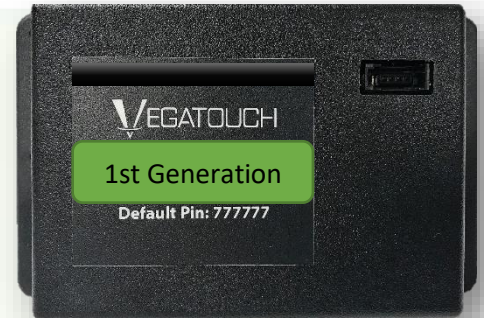



Vegatouch Mira Setup

Notice: Make sure that Bluetooth is turned ON in your smart device settings before proceeding.

Locate the Login Information:

The login information can be found by clicking on the Mobile App button on the settings page of the touchscreen or from the Mira module's label.



Download:

Download Vegatouch Mira from the Google Play store or the App Store. Once the download has finished, install the app and open it.



Setup:

Tap SCAN to find the Mira Module's signal. After scanning, any Mira Module in your area will appear on the screen. Tap the ID # that matches the one on your Mira label. Enter the PIN number from the Mira label and press AUTHENTICATE to connect to the system.

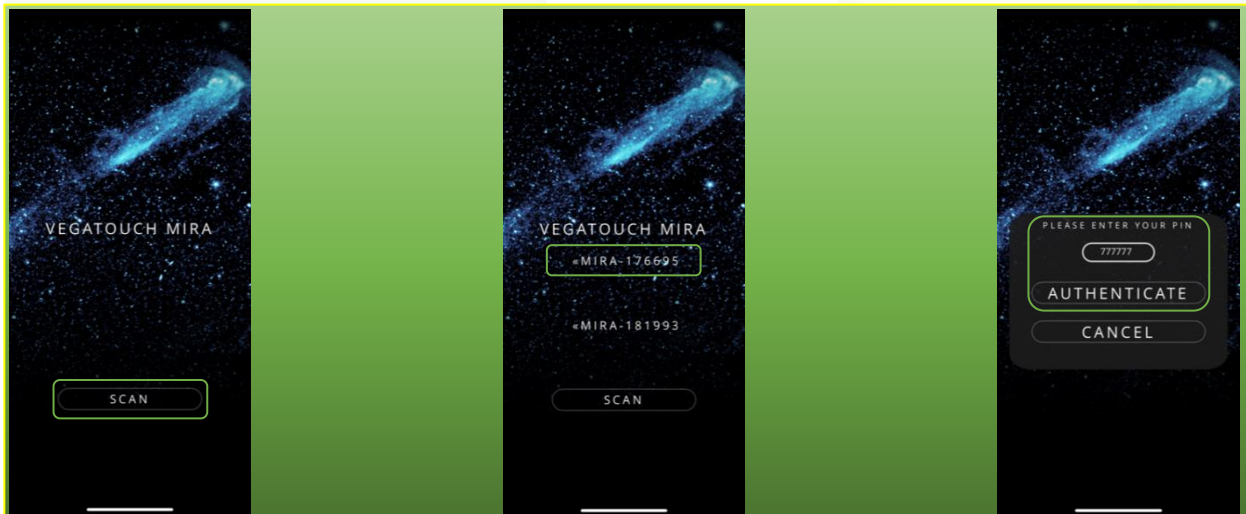

Notice: iOS Setup Tips

Turn on Bluetooth to allow Vegatouch Mira to connect to Accessories.

If you do not have Bluetooth turned ON in your iOS settings you will see this screen. Do not click OK, you must click SETTINGS. Your Bluetooth Settings page will now appear and you should turn Bluetooth ON.

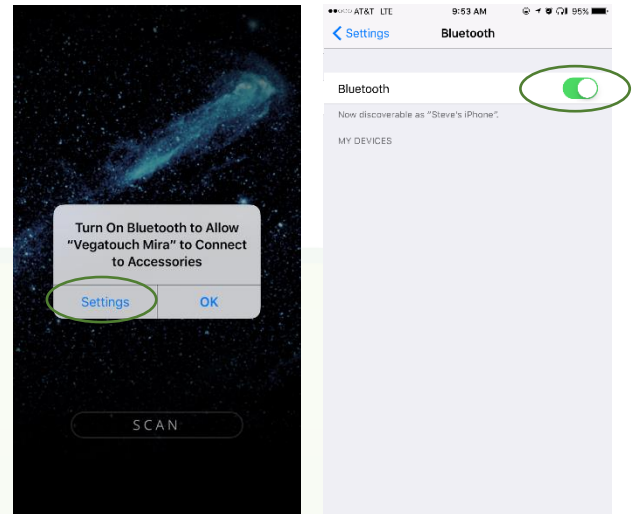

Notice: Android Setup Tips

Allow Vegatouch Mira to access this device's location.

Mira will need to be allowed access to your location. Click ALLOW when you see this screen.

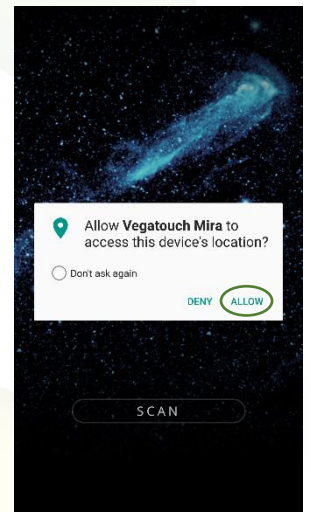

App Settings:

Access the App Settings page by tapping the triangle (at the bottom of the screen) to expose the Settings button. Tap the gear to visit the settings page.

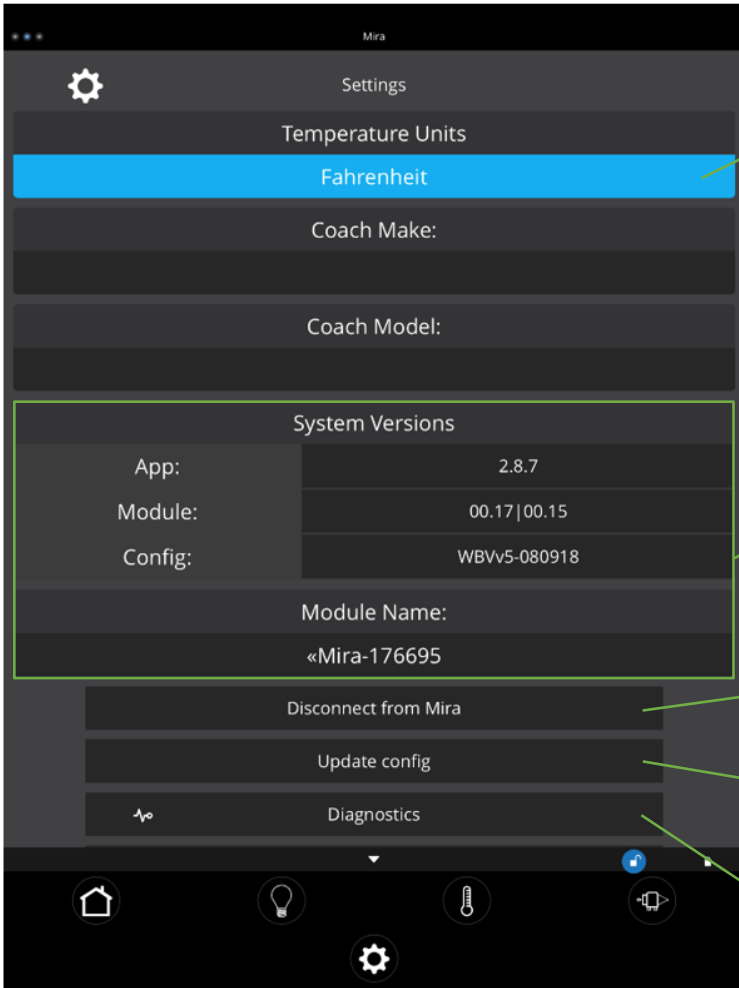
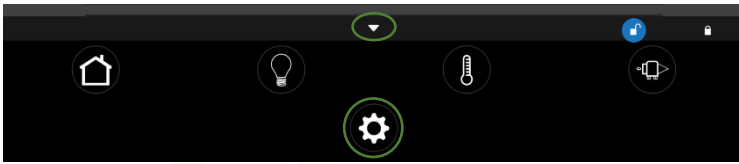

Tap to Temperature Units selection to choose between Fahrenheit and Celsius.

System Information and Mira Name.

Tap to disconnect your device from Mira.

Tapping Update Config will force a download of the config from the cloud.

Tap to enter the Diagnostic Tools screen.



Vegatouch Pluto

Vegatouch Pluto is a wireless control module that easily connects to any Android or iOS device to give total control to many electrical, electronic and mechanical systems in your coach. Pair any device with the coach’s built-in interface to monitor and control every component.

It is important to note that there is no external NET LED on this device. To install the hardware, simply connect a network cable to the Net Port on this device.



NET PORT



Download the FREE Vegatouch Pluto App from the APP STORE or GOOGLE PLAY.

Pluto connects to your phone via WIFI. To setup Pluto, simply connect your phone to Pluto’s WIFI signal (just as you would at a WIFI hotspot) and enter the pin located on the MOBILE APP page.

MY PHONE SHOWS AN IMAGE OF PLUTO AND SAYS “DOWNLOAD COMPLETE” BUT NOTHING HAPPENS.

If you see this image, you are not currently connected to Pluto’s WIFI. Open your phone’s WIFI settings and try connecting again.



THE CONNECTION SCREEN ONLY SHOWS DASHES.

If only dashes display for the login info, Pluto is not currently connected to the network. Check the network drop cable connections from the Pluto module to the network. Replace the cable if necessary. *





Network Troubleshooting



Resistance Test:

If you suspect a network issue, the first test to do is a resistance test. Take a multimeter and turn it to OHMS. The reading can be taken anywhere CAN L and CAN H are present.

The easiest place to take this measurement will be on a trunk cable connector (Fig 1), which can be found on the RSI-9 if installed in the coach.

POWER MUST BE TURNED OFF TO THE ENTIRE COACH!











If the coach comes with an RSI-9 but does not include a trunk cable connector, simply place the probes on CAN L and CAN H of the trunk port (Fig 2).



Put 1 probe on CAN L and the other on CAN H. Your reading should be around 60 OHMS. If the reading is around 120 OHMS, there is usually only one terminator in the system. If you get 120 OHMS, make sure both terminators are connected to all wires appropriately, then retest.

Keep in mind that if the drop/trunk cable running from the terminator back to the trunk connection has the network connection interrupted, the terminator can no longer add resistance to the system.

Panel Network Status Indicator – Applies to any device with a network indicator:

-  /  Fast flashing Green Light (4 times/sec) – Device is attempting to make initial connection.
-  /  Slow flashing Green Light (1 time/sec) – Device was online but has been offline for at least 5 sec.
-  Solid Green – Device is connected to network and is communicating properly.
-  Solid Red – Device has gone offline and is not connected to a network.
-  /  Alternating Red & Orange – Device has gone offline and is trying to re-connect (within 30 sec).
-  /  Alternating Green & Orange – Device is currently online but has gone offline 2 or more times.

NOTE: It is very helpful to have an accurate Network Wiring Diagram (NWD) to follow while troubleshooting network wiring issues. These are available from Firefly Integrations.

All devices (switch panels and control panels/modules) instantly go offline (SOLID RED) as soon as the network is powered up.

Verify all CAN network measurements (as outlined above) at various points throughout the network.

- CAN H and CAN L voltage measurements out of range.
 - This is usually caused by a short to 12V, ground or between CAN H and CAN L. Begin isolating parts of the trunk and drop cable to locate the issue.
 - Various devices on the network can also be unplugged to follow the process of elimination to determine if there is a specific device causing the problem.

Carefully check each of the connectors at every drop tap and device to verify the proper wire order/pinout as listed above.

- A pair of CAN H and CAN L wires in the wrong order on the connector will cause devices to go offline even though the network measurements will be in the proper range.

Multiple devices go offline over a period of time or whenever there is significant network activity (i.e. – Light Master or Shades Master buttons are pressed).

Intermittent network performance is typically caused by one or more of the following:

- Drop cables that exceed the 20ft drop length from the main trunk line.
- Improper installation or location of the network terminators.
- Poor grounds on devices that are not network powered located throughout the coach (not using the same ground as the Network powered components).
- Use of non-CAN specification network cable.
- Voltage loss at the ends of the network due to poor connections, improper power supply, low battery voltage or excessive trunk or drop cable lengths.

A single device does not connect or goes offline in the installed location but works when plugged directly into the NET PORT on the front of your DC Panel.

Verify the drop cable connector/termination for that specific location using the connector diagrams and network measurements shown above.

Check for a damaged drop cable or drop tap for that location.



Technical Support

Technical Support is available Monday – Friday, 8:00am – 4:30pm EST.

Firefly Integrations

1013 Elroy Drive
Middlebury, Indiana 46540

Phone: (574) 825-4600

Support@fireflyint.com

www.fireflyintegrations.com

Follow us on Facebook @Fireflyintegrations



WARRANTY PROCEDURES

Firefly Integrations, LLC (hereafter FFI) endeavors to use high quality components in the development of our advanced 12V electrical systems. Our products are thoroughly tested prior to shipment. This permits FFI to offer a guarantee against defects in workmanship on FFI system parts.

No other express warranty applies: This warranty is the sole and exclusive warranty. No employee, agent, dealer, or other person is authorized to alter this warranty or make any other warranty on behalf of FFI.

What is Covered?

- a. This warranty covers any defects in materials or workmanship during the warranty period, excluding any and all exemptions stated below.

How Long Does Coverage Last?

- a. This warranty lasts for a period of one (1) year from the date of retail sale of the coach.
- b. This warranty is limited to a maximum of two (2) years from original installation by a qualified professional if the coach is not sold within 12 months of the manufacturing date.

What is Not Covered? (Exemptions)

- a. Products that have been altered, modified, repaired, or serviced by anyone other than the service facilities authorized by FFI to render such services.
- b. Products with serial numbers or other distinguishing numbers or codes that have been altered or removed.
- c. Products that have been subject to accident, misuse, abuse, fire, water damage, acts of God, improper installation, or operated contrary to the instructions contained in the Owner's Manual, at any time before or after original installation.
- d. Damage by operation beyond the specifications of the product. (i.e. using inappropriate fuse size, etc.)
- e. Use of any other network wiring other than FFI network wiring; other network wiring will damage the FFI system and will effectively void the warranty on the part(s) and/or system.
- f. Labor and/or expenses incurred.

What Will FFI Do?

- a. Run a diagnosis of each returned item.
- b. Repair or replace any defective parts. Replacement parts may be new or refurbished at FFI's sole discretion.
- c. Alternatively, at FFI's sole discretion, FFI **may** provide a credit for returned part(s), not exceeding the original sale value of the returned part(s), if this method is agreed upon prior to the return. Credit will not be issued until the return has been received by FFI and diagnosis of the returned part(s) has been completed.

How to Get Service

- a. Contact FFI via email at warranty@fireflyint.com to receive a Return Goods Authorization (RGA). A RGA must be obtained before any product can be returned to FFI.
- b. Once the RGA has been assigned by FFI, the RGA must be referenced on the paperwork to be returned.

Delivery of Returned Item(s)

- a. The Returnee is responsible for packaging the returned part(s) appropriately, with sufficient protection against shipping damage; FFI will not be responsible for any damage to the returned part(s) due to improper packaging.
- b. It is the returnee's responsibility to provide a description of the problem and/or diagnosis, unit number from which the returned part(s) are from, and the correct address to ship the repaired and/or replaced products to.
- c. The repaired or replaced part(s) will be returned from FFI freight prepaid via UPS Ground.

Diagnosis Testing

- a. If part(s) being replaced are within the timeline of the Firefly Warranty, but testing the returned part(s) during diagnosis proves the item(s) to be either without defect or non-warrantable, all costs and shipping charges of the part(s) will be charged to the recipient of the part(s).

Please contact your coach Manufacturer for their specific warranty procedures.